

# The Harman Kardon Model PM650

Manual No. 22A

## HI-CURRENT CAPABILITY INTEGRATED AMPLIFIER

# Technical Manual

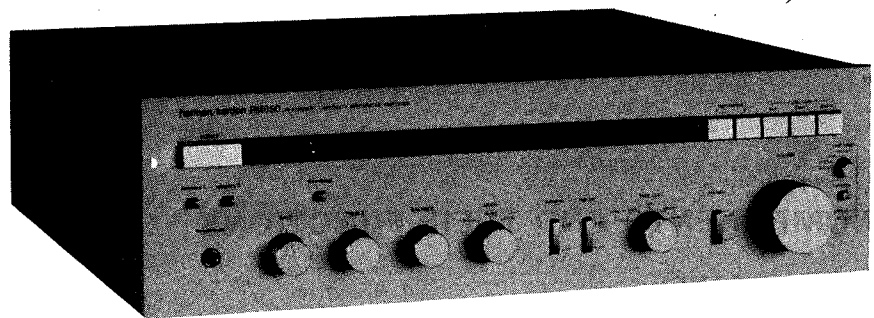

PM650

**harman/kardon**

240 CROSSWAYS PARK WEST, WOODBURY, N.Y. 11797  
PRINTED IN JAPAN 1112-H15222A8 P-07819

## CONTENTS

SPECIFICATIONS .....	2	WIRING DIAGRAM .....	8
COMPONENTS AND THEIR FUNCTIONS		P.C. BOARDS .....	9,10
FRONT PANEL .....	2,3	GENERAL UNIT EXPLODED VIEW .....	11
REAR PANEL .....	4	GENERAL UNIT PARTS LIST .....	12
DISASSEMBLY PROCEDURES .....	5	ELECTRICAL PARTS LIST .....	13-16
ALIGNMENT PROCEDURES .....	6	PACKAGE .....	16
SCHEMATIC DIAGRAM .....	7		

## SPECIFICATIONS

R.M.S. Power Output: 50W+50W at 0.08% T.H.D. (8Ω)  
 Frequency Response (-3dB): 0.5Hz ~140kHz  
 IM Distortion: Less than 0.1%  
 Slew Rate: 100V/μsec.  
 Overall Negative Feedback: 15dB  
 S/N (IHF-A) Phono: 78dB  
           AUX: 80dB  
 Phono Overload MM: More than 220mV at 1kHz  
                   MC: More than 5mV at 1kHz

Semiconductors: 83 Transistors, 2 FETs,  
 8 Diodes, 17 Zener Diodes,  
 3 Bridge Silicon Diodes,  
 2 Varistors

Power Supply: AC 120V, 60Hz  
 Power Consumption: 350W, 390VA  
 Dimensions: 440(W) x 122(H) x 360(D)mm  
                   (17-5/16" x 4-13/16" x 14-3/16")  
 Weight: 10.4kg. (301bs. 13oz.)

Specifications and components subject to change without notice.  
 Overall performance will be maintained or improved.

## COMPONENTS AND THEIR FUNCTIONS

### ■ FRONT PANEL

PM650

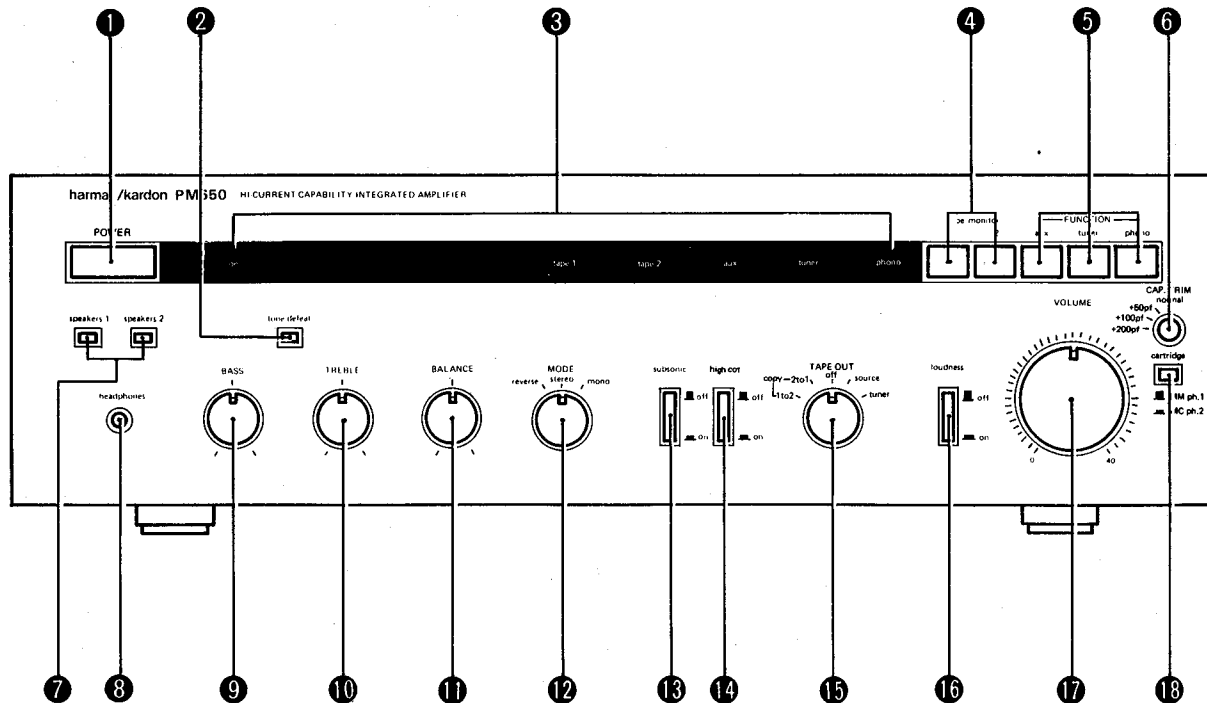

**1 POWER SWITCH (POWER)**

For power on and off.

When this switch is pressed after AC cord connection to an outlet, the DISPLAY PANEL indicates "on" in red color. Press this switch again to turn the power off.

**2 TONE DEFEAT SWITCH (tone defeat)**

For defeating tone control by TONE CONTROL knobs (BASS, TREBLE).

At the depressed position, flat frequency characteristic is obtained irrespective of TONE CONTROL knob positions.

**3 DISPLAY PANEL**

(on / tape 1 / tape 2 / aux / tuner / phono)

The DISPLAY PANEL indicates the current status of the unit.

**4 TAPE MONITOR SWITCHES (tape monitor 1,2)**

For monitoring the equalizer or tape deck connected to the TAPE 1 INPUT/OUTPUT jacks or TAPE 2 INPUT/OUTPUT jacks.

The monitored tape deck is displayed as "tape 1" or "tape 2" in red color on the DISPLAY panel.

**5 FUNCTION SELECTORS (FUNCTION)****AUX switch:**

Press this switch to select the program source connected to the AUX INPUT jacks.

**TUNER switch:**

Press this switch to select the tuner connected to the TUNER INPUT jacks.

**PHONO switch:**

Press this switch to select the turntable connected to the PHONO INPUT 1 or 2 jacks.

The selected function is indicated as "aux", "tuner" or "phono" in green color on the DISPLAY PANEL.

**6 CAPACITANCE TRIM SELECTOR (CAP. TRIM)**

For adjustment of the capacitance of the cartridge of your turntable connected to the PHONO 1 INPUT jacks.

Set this knob as follows:

Cartridge capacitance	Position
0 - 300pF	normal
300 - 350pF	+50pf
350 - 400pF	+100pf
Over 400pF	+200pf

**7 SPEAKER SELECTORS (speakers 1, speakers 2)**

For selection of speakers to be sounded.

2 speaker systems can be connected to this unit. When listening to speaker sound, depress the corresponding selector. To sound both speaker systems, depress both switches. Release the switch to listen with headphones only.

**8 STEREO HEADPHONES JACK (headphones)**

For connection of stereo headphones.

Output signal is always supplied to this jack.

**9 BASS CONTROL KNOB (BASS)**

For emphasis or attenuation of low-pitched tone.

Turn it clockwise for emphasis, or counterclockwise for attenuation.

**10 TREBLE CONTROL KNOB (TREBLE)**

For emphasis or attenuation of high-pitched tone.

Turn it clockwise for emphasis, or counterclockwise for attenuation.

**11 BALANCE CONTROL KNOB (BALANCE)**

For balance adjustment between left and right channels. Normally place it at the center position.

**12 MODE SELECTOR (MODE)****MONO position:**

Select this position for a monaural source program.

**STEREO position:**

Select this position for stereo playback, reception or recording.

**REVERSE position:**

Select this position to reverse the right and left channel signals.

**13 SUBSONIC FILTER SWITCH (subsonic)**

For filtering very low frequencies.

When depressed, the subsonic filter is validated to prevent distortion resulting from turntable rumble and speaker damage caused by superlow tones.

**14 HIGH CUT FILTER SWITCH (high cut)**

For attenuation of high frequency noise.

At depressed position, the high cut filter is validated to cut off high frequency noise such as tape hissing sound.

**15 TAPE OUT SELECTOR (TAPE OUT)****TUNER position:**

The tuner signals appear at TAPE 1/2 OUTPUT jacks irrespective of the selected function. This position enables listening to turntable or the source connected to the AUX INPUT jacks while recording a broadcasting program (air check).

**SOURCE position:**

The signals of the source selected by the FUNCTION selector appear at the TAPE 1/2 OUTPUT jacks.

**OFF position:**

During tape playback or listening to a program source selected by the FUNCTION selector, the output signals to the TAPE 1/2 OUTPUT jacks are cut off to prevent sound degradation.

**COPY-2 TO 1 position:**

Enables dubbing from the tape deck connected to TAPE 2 INPUT jacks to the deck connected to TAPE 1 OUTPUT jacks.

To monitor the source tape sound, press the TAPE MONITOR 2 switch. To monitor the sound being recorded, press the TAPE MONITOR 1 switch.

When the FUNCTION switch (AUX, TUNER or PHONO) is pressed with the TAPE MONITOR switches OFF, you can enjoy the selected source sound while copying the tape (dubbing).

**COPY-1 TO 2 position:**

Reverse of the above position.

**16 LOUDNESS SWITCH (loudness)**

For emphasis of the low and high frequency ranges to enable impressive reproduction when listening at a low sound volume.

**17 VOLUME CONTROL KNOB (VOLUME)**

For increase/decrease of the sound volume.

Clockwise turn increases the sound volume, and counterclockwise turn decreases it. Set this knob at a minimum level before turning the power on to prevent speaker from being damaged by a sudden booming sound.

**18 CARTRIDGE SELECTOR (cartridge)**

For selection between MM and MC type cartridges. If your turntable uses an MC type cartridge, connect it to the PHONO 2 INPUT jacks and depress this switch. If your turntable uses an MM type cartridge, connect it to the PHONO 1 INPUT jacks and release this switch.

## COMPONENTS AND THEIR FUNCTIONS

## ▪ REAR PANEL

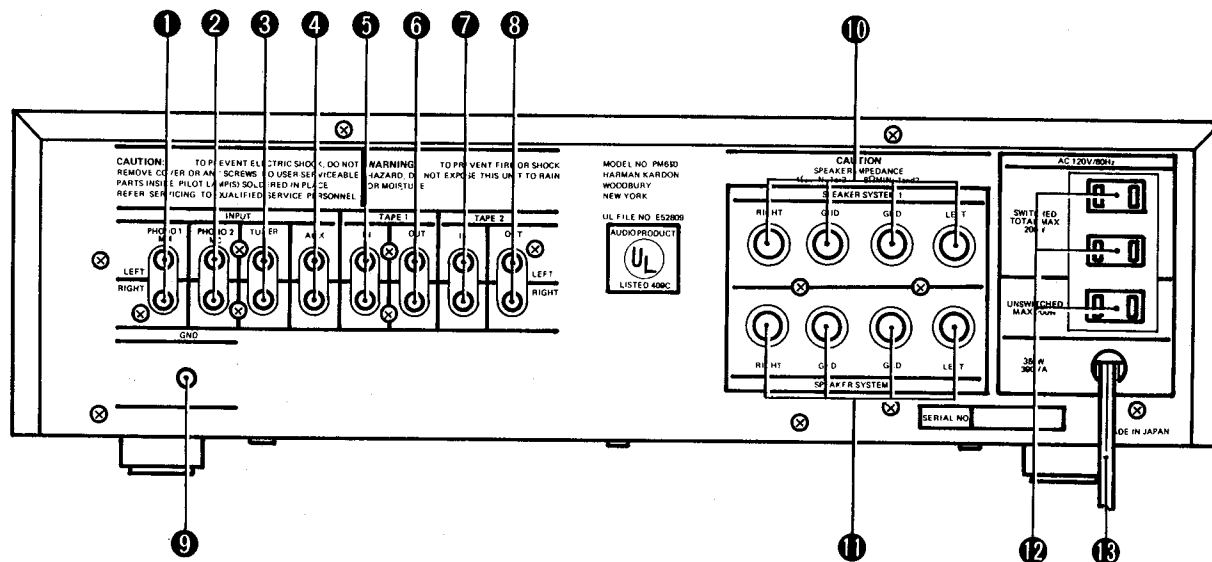
**1 PHONO 1 INPUT JACKS (INPUT PHONO 1 MM)**

Connect the output cables from your turntable using an MM type cartridge here.

**2 PHONO 2 INPUT JACKS (INPUT PHONO 2 MC)**

Connect the output cables from your turntable using an MC type cartridge here.

**NOTE:** When using either PHONO 1 or PHONO 2 INPUT jacks, please insert the attached SHORTING PLUGS into the PHONO INPUT jacks not in use.

**3 TUNER INPUT JACKS (INPUT TUNER)**

Connect the output cables from your tuner here.

**4 AUX INPUT JACKS (INPUT AUX)**

Connect the output cables from your TV tuner, etc. here.

**5 TAPE 1 INPUT JACKS (TAPE 1 IN)**

Connect the output cables from your tape deck or equalizer here.

**6 TAPE 1 OUTPUT JACKS (TAPE 1 OUT)**

Connect the input cables to your tape deck or equalizer here.

**7 TAPE 2 INPUT JACKS (TAPE 2 IN)**

Connect the output cables from another tape deck here.

**8 TAPE 2 OUTPUT JACKS (TAPE 2 OUT)**

Connect the input cables to another tape deck here.

**9 GROUND TERMINAL (GND)**

Connect the grounding cable from your turntable here.

**10 SPEAKER SYSTEM 1 CONNECTORS (SPEAKER SYSTEM 1)**

Connect the cables for your speaker system here. Carefully connect speaker cables so as not to mistake left and right channels and polarities.

**11 SPEAKER SYSTEM 2 CONNECTORS (SPEAKER SYSTEM 2)**

Connect the cables for the second speaker system here in the same way as explained for the first SPEAKER SYSTEM.

When using one speaker system, it may be connected to either SPEAKER SYSTEM 1 connectors or SPEAKER SYSTEM 2 connectors.

**CAUTION:**

2 speaker systems can be connected to this unit.

The minimum speaker impedance shall be  $4\Omega$  when only one speaker system is used, or  $8\Omega$  when two speaker systems are used.

**12 AC CONVENIENCE OUTLETS****SWITCHED:**

Use these outlets to connect your turntable, tuner, cassette deck and/or other components. The power supply to the connected components is interlocked with power on/off of this unit. The total maximum capacity is 200W.

**UNSWITCHED:**

This outlet is always supplied with the power regardless of the position of the POWER switch of this unit. Interlocked on/off of the connected component is impossible. The maximum capacity is 200W.

**13 AC CORD**

Connect this cord to mains outlet. Be sure to turn off the POWER switch before connecting the AC cord.

## DISASSEMBLY PROCEDURES

### CABINET TOP REMOVAL (Fig. 1)

1. Remove 10 black colored screws ① to ⑩ fixing cabinet top.
2. Slide the cabinet top backward gradually to remove.

### CABINET BOTTOM ASSEMBLY REMOVAL (Fig. 1)

3. Remove 11 screws ⑪ to ⑳ from the cabinet bottom and remove the cabinet bottom assembly.

### FRONT PANEL ASSEMBLY REMOVAL (Fig. 1)

4. Complete steps 1 and 2.
5. Pull off the Volume knob.
6. Remove 6 screws ㉒ to ㉗ fixing front panel.
7. Pull the front panel assembly toward you to remove.

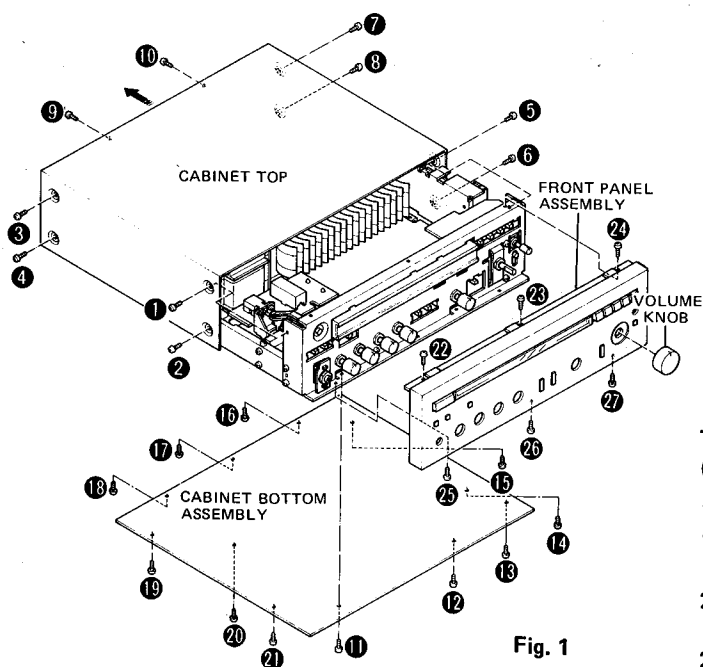

Fig. 1

### FRONT CHASSIS WITH P.C. BOARD ASSEMBLIES REMOVAL (Fig. 2)

8. Complete steps 1 through 7.
9. Pull off the Cap. Trim knob.
10. Remove a nut fixing the capacitance trim switch with P.C. board and detach from the front chassis.
11. Remove 7 screws ① to ⑦ fixing the front chassis.
12. Remove the front chassis while watching out lead wires and the parts around.  
Remove the lead wires, if necessary.

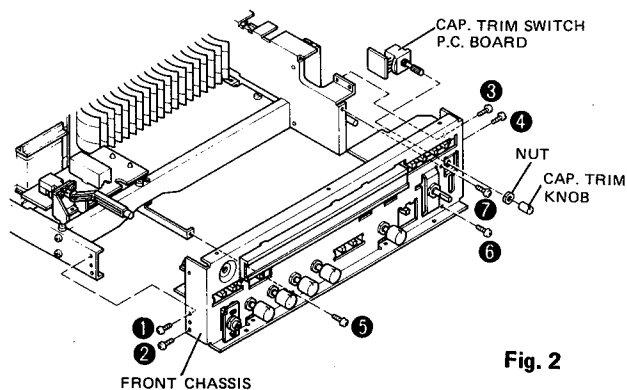

Fig. 2

### INDICATION LAMP REFLECTOR REMOVAL (Fig. 3).

13. Complete steps 4 through 7.
14. Since the indication plate in front of the reflector is only fit into the edge of the reflector, strip the edge along the reflector and slide the indication plate right or left to remove.
15. As the reflector is only fit into the front chassis, remove the reflector while pushing the fit-in part. In this case, pay attention not to damage the indication lamp for power and function lamps.

### POWER AND FUNCTION INDICATION LAMPS REMOVAL (Fig.3)

16. Complete steps 1 and 2.
17. Insert a screwdriver for slotted screw from the printed side of the P.C. board and turn it counterclockwise.

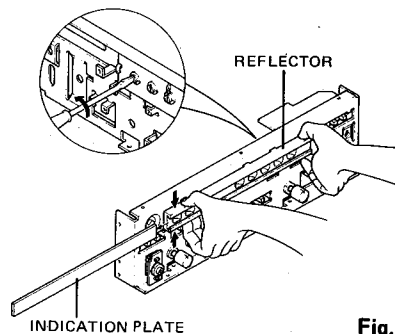

Fig. 3

### TONE CONTROL P.C. BOARD ASSEMBLY REMOVAL (Fig. 4)

18. Complete steps 8 through 12.
19. Pull off the Bass, Treble, Balance, Mode selector and Tape Out knobs.
20. Remove 5 nuts fixing bass, treble and balance controllers, and mode selector and tape out switches.
21. Remove 4 screws ① to ④ fixing subsonic, high cut and loudness switches and take out P.C. board.

### VOLUME CONTROL P.C. BOARD ASSEMBLY REMOVAL (Fig. 4)

22. Complete steps 8 through 12.
23. Remove a nut fixing volume control with P.C. board and remove it.

### INDICATION LAMP P.C. BOARD ASSEMBLY REMOVAL (Fig. 4)

24. Complete steps 8 through 12.
25. Raise up the 5 pawls fixing indication lamp P.C. board to free the P.C. board.

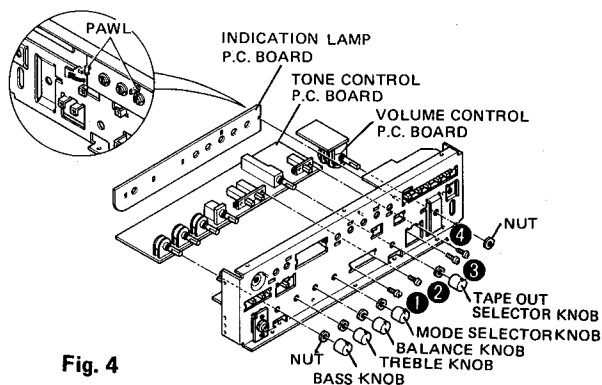

Fig. 4

# ALIGNMENT PROCEDURES

## IDLING CURRENT ADJUSTMENT

**Instrument:** DC Voltmeter

- Notes:**
1. Set function selector switch to AUX position.
  2. Set volume control to minimum position.
  3. Proceed with the adjustment at least 20 minutes after the power has been switched on to stabilize idling current.

Step	Connect Output Meter To	Adjust	Adjust For
1	DC voltmeter to TP1 (+) and TP2 (-)	VR403	33mV on DC voltmeter
2	DC voltmeter to TP3 (+) and TP4 (-)	VR404	Same as above

## DC VOLTAGE BALANCE ADJUSTMENT

**Instrument:** DC Voltmeter

- Notes:**
1. Set function selector switch to AUX position.
  2. Set volume control to minimum position.
  3. Press in speakers 1 push button to ON position.
  4. Proceed with the adjustment at least 20 minutes after the power has been switched on to stabilize idling current.

Step	Connect Output Meter To	Adjust	Adjust For
1	DC voltmeter to Lch terminal of Speaker System 1	VR401	0V±10mV on DC voltmeter
2	DC voltmeter to Rch terminal of Speaker System 1	VR402	Same as above

## ALIGNMENT POINTS LOCATION

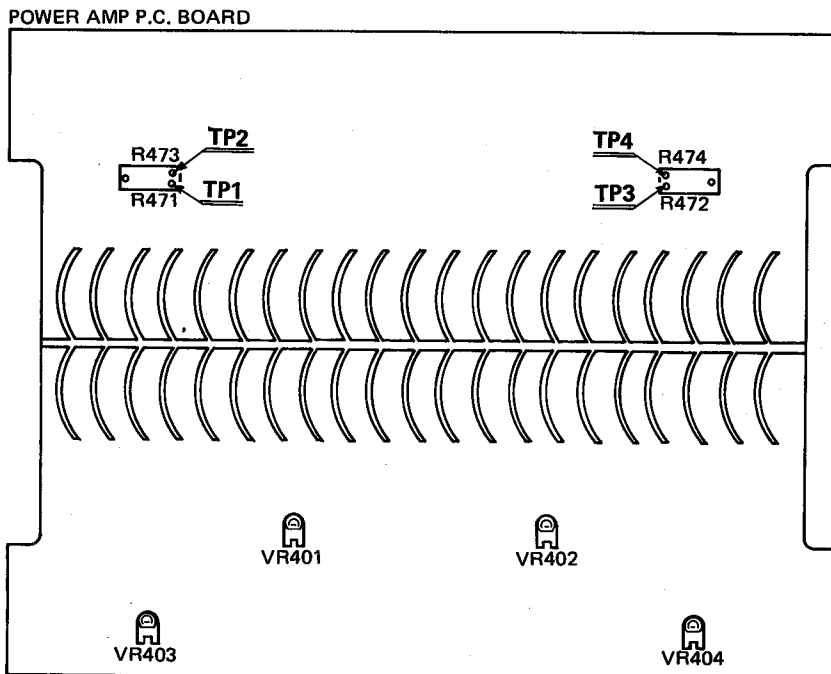

SCHEMATIC DIAGRAM

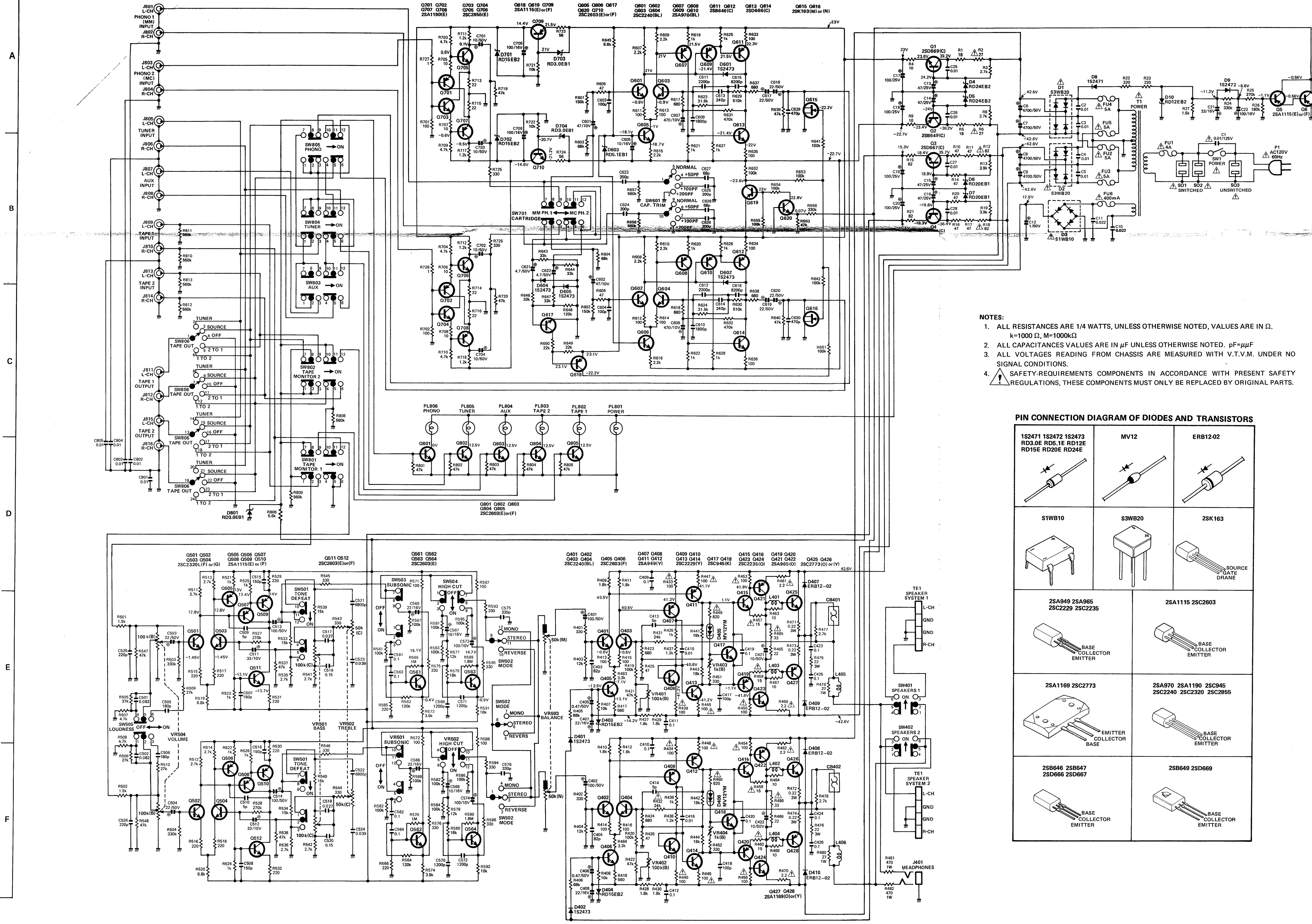

- NOTES:
- ALL RESISTANCES ARE 1/4 WATTS, UNLESS OTHERWISE NOTED, VALUES ARE IN  $\Omega$ .  
 $k=1000 \Omega$ ,  $M=1000k\Omega$
  - ALL CAPACITANCES VALUES ARE IN  $\mu F$  UNLESS OTHERWISE NOTED.  $pF=\mu\mu F$
  - ALL VOLTAGES READING FROM CHASSIS ARE MEASURED WITH V.T.V.M. UNDER NO SIGNAL CONDITIONS.
  - SAFETY-REQUIREMENTS COMPONENTS IN ACCORDANCE WITH PRESENT SAFETY REGULATIONS, THESE COMPONENTS MUST ONLY BE REPLACED BY ORIGINAL PARTS.

PIN CONNECTION DIAGRAM OF DIODES AND TRANSISTORS

<p>1S2471 1S2472 1S2473 RD3.0E RD5.1E RD12E RD15E RD20E RD24E</p>	<p>MV12</p>	<p>ERB12-02</p>
<p>S1WB10</p>	<p>S3WB20</p>	<p>2SK163</p>
<p>2SA949 2SA965 2SC2229 2SC2235</p>	<p>2SA1115 2SC2603</p>	<p>BASE COLLECTOR EMITTER</p>
<p>2SA1169 2SC2773</p>	<p>2SA970 2SA1190 2SC945 2SC2240 2SC2320 2SC2855</p>	<p>BASE COLLECTOR EMITTER</p>
<p>2SB646 2SB647 2SD666 2SD667</p>	<p>2SB649 2SD669</p>	<p>BASE COLLECTOR EMITTER</p>

# SCHEMATIC DIAGRAM

A

B

C

D

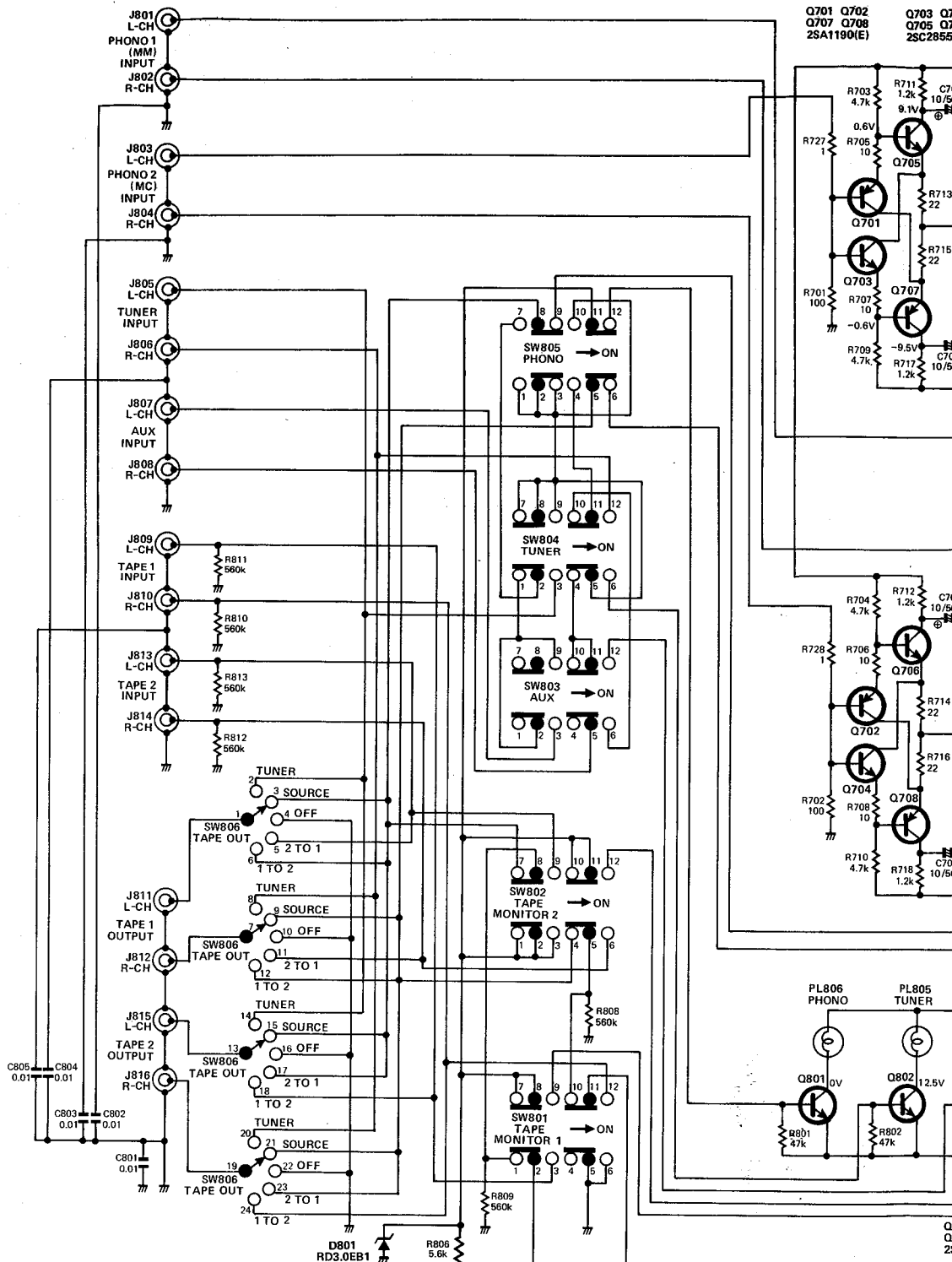

Q701	Q702	Q703	Q704
2SA1190(E)	2SA1190(E)	2SC2855	2SC2855

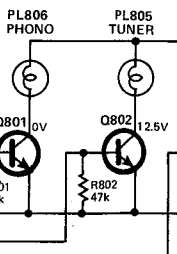
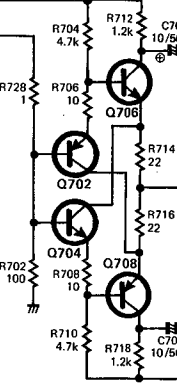
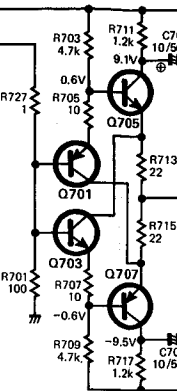

Q501	Q502	Q505	Q506	Q507	Q511	Q512
2SC2320(L) or (G)	2SC2320(L) or (G)	Q508	Q509	Q510	2SC2603(E) or (F)	2SC2603(E) or (F)

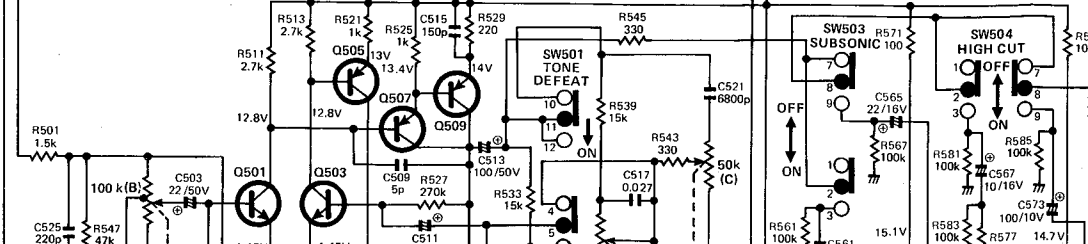



Q703 Q704 Q705 Q706 2SC2855(E)  
 O618 O619 O709 2SA1115(E) or (F)  
 O605 O606 O617 O820 O710 2SC2603(E) or (F)  
 O601 O602 O603 O604 O607 O608 O609 O610 2SA970(BL)  
 O611 O612 2SB646(C)  
 O613 O614 2SD666(C)  
 O615 O616 2SK163(M) or (N)

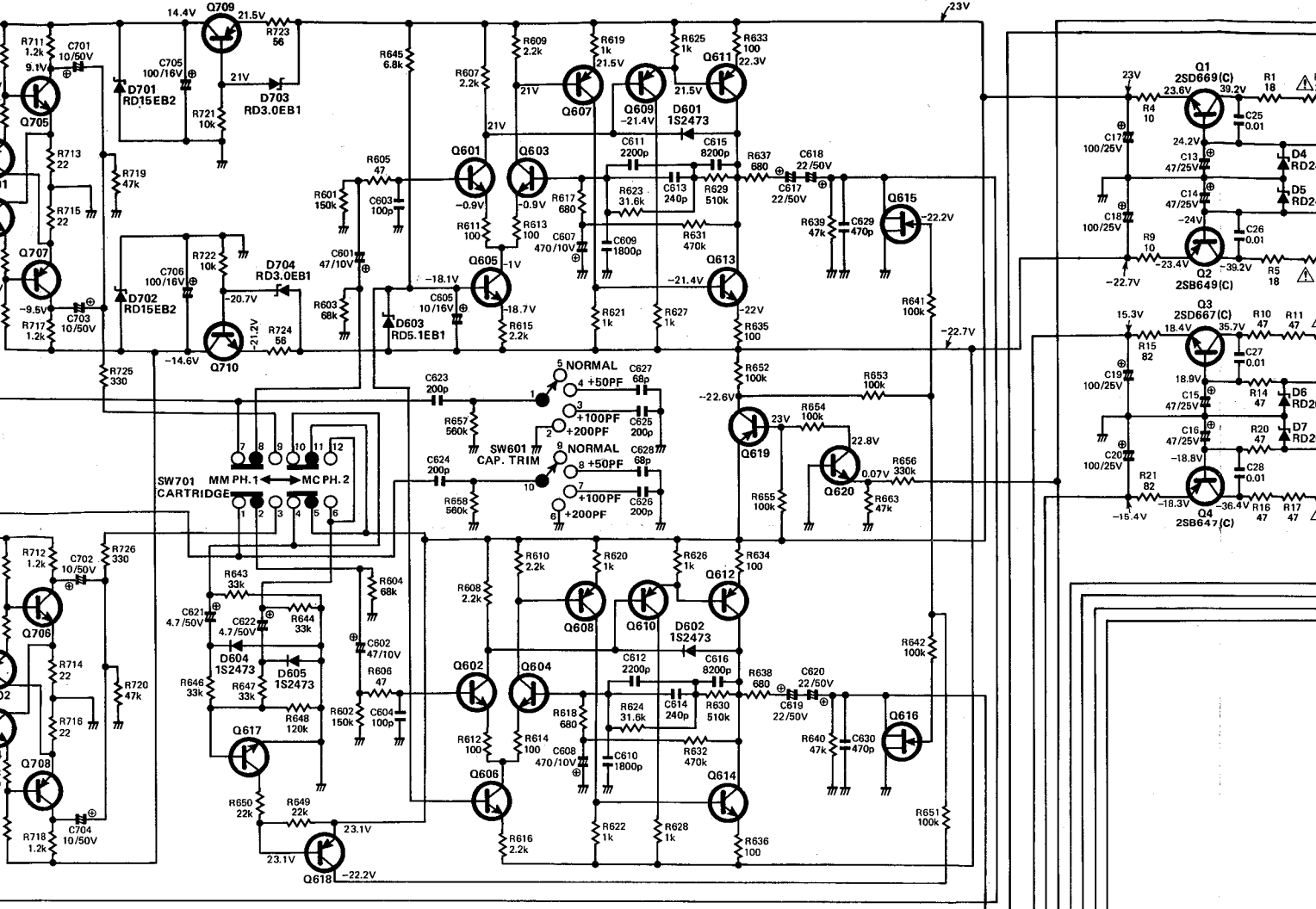

PL805 TUNER  
 PL804 AUX  
 PL803 TAPE 2  
 PL802 TAPE 1  
 PL801 POWER

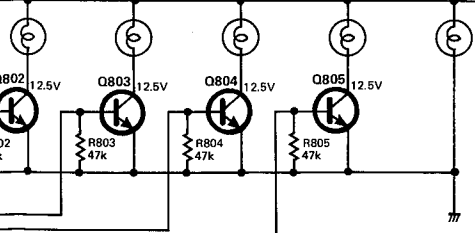

Q801 Q802 Q803 Q804 Q805 2SC2603(E) or (F)

W504 H CUT OFF  
 Q401 Q402 Q403 Q404 2SC2240(BL)  
 Q405 Q406 2SC2603(F)  
 Q407 Q408 Q411 Q412 2SA949(V)  
 Q409 Q410 Q413 Q414 2SC2229(V)  
 Q417 Q418 2SC945(K)  
 Q415 Q416 Q423 Q424 2SC2235(O)  
 Q419 Q420 Q421 Q422 2SA965(O)  
 Q425 Q426 2SC2773(O) or (Y)  
 42.5V

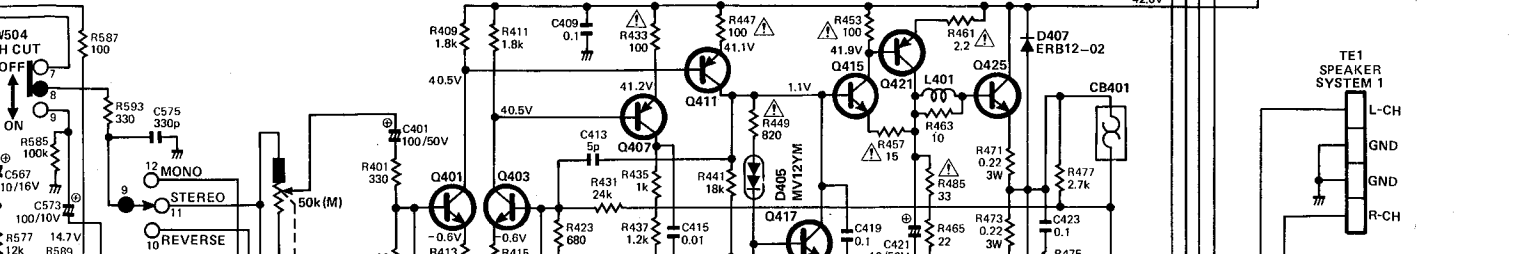



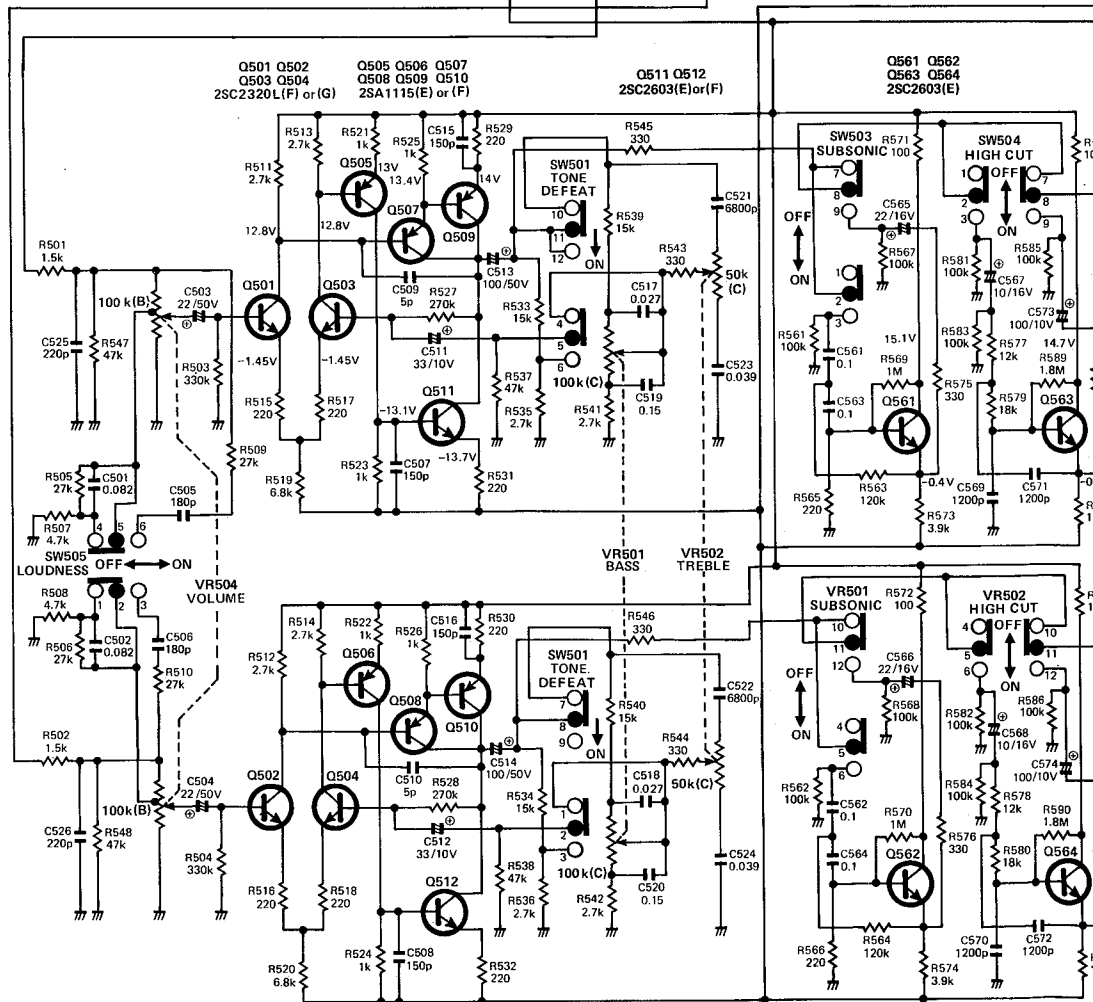
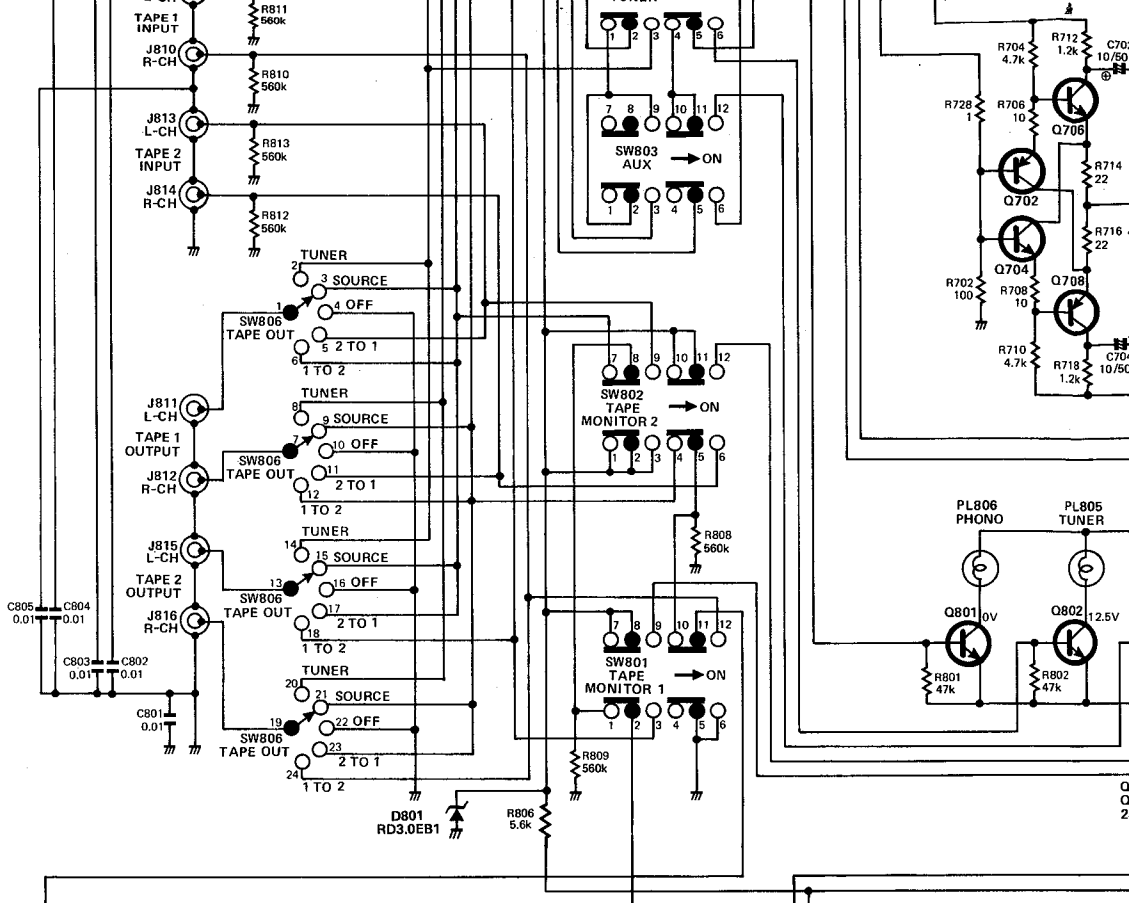

C

D

E

F



**NOTES:**

1. ALL RESISTANCES ARE 1/4 WATTS, UNLESS OTHERWISE NOTED, VALUES ARE IN  $\Omega$ .  
k=1000  $\Omega$ , M=1000k $\Omega$
2. ALL CAPACITANCES VALUES ARE IN  $\mu$ F UNLESS OTHERWISE NOTED. pF= $\mu$  $\mu$ F
3. ALL VOLTAGES READING FROM CHASSIS ARE MEASURED WITH V.T.V.M. UNDER NO SIGNAL CONDITIONS.
4.  SAFETY-REQUIREMENTS COMPONENTS IN ACCORDANCE WITH PRESENT SAFETY REGULATIONS, THESE COMPONENTS MUST ONLY BE REPLACED BY ORIGINAL PARTS.

**PIN CONNECTION DIAGRAM OF DIODES AND TRANSISTORS**

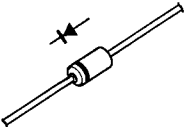
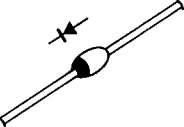
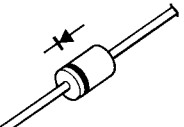
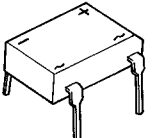
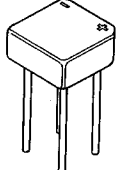
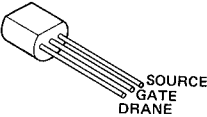
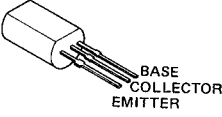
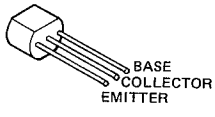
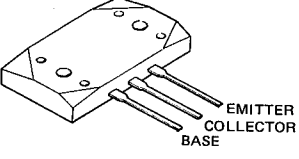
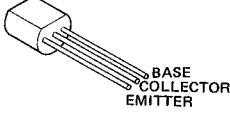
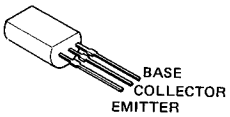
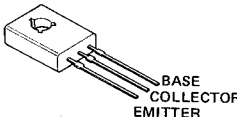
<p>1S2471 1S2472 1S2473 RD3.0E RD5.1E RD12E RD15E RD20E RD24E</p> 	<p>MV12</p> 	<p>ERB12-02</p> 
<p>S1WB10</p> 	<p>S3WB20</p> 	<p>2SK163</p> 
<p>2SA949 2SA965 2SC2229 2SC2235</p> 		<p>2SA1115 2SC2603</p> 
<p>2SA1169 2SC2773</p> 		<p>2SA970 2SA1190 2SC945 2SC2240 2SC2320 2SC2855</p> 
<p>2SB646 2SB647 2SD666 2SD667</p> 		<p>2SB649 2SD669</p> 

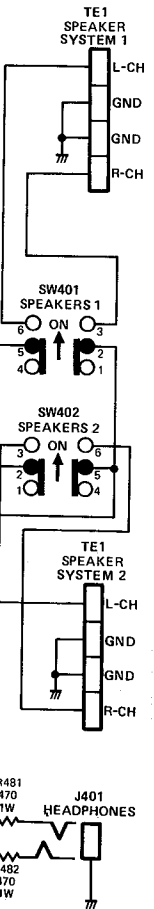

WIRING DIAGRAM

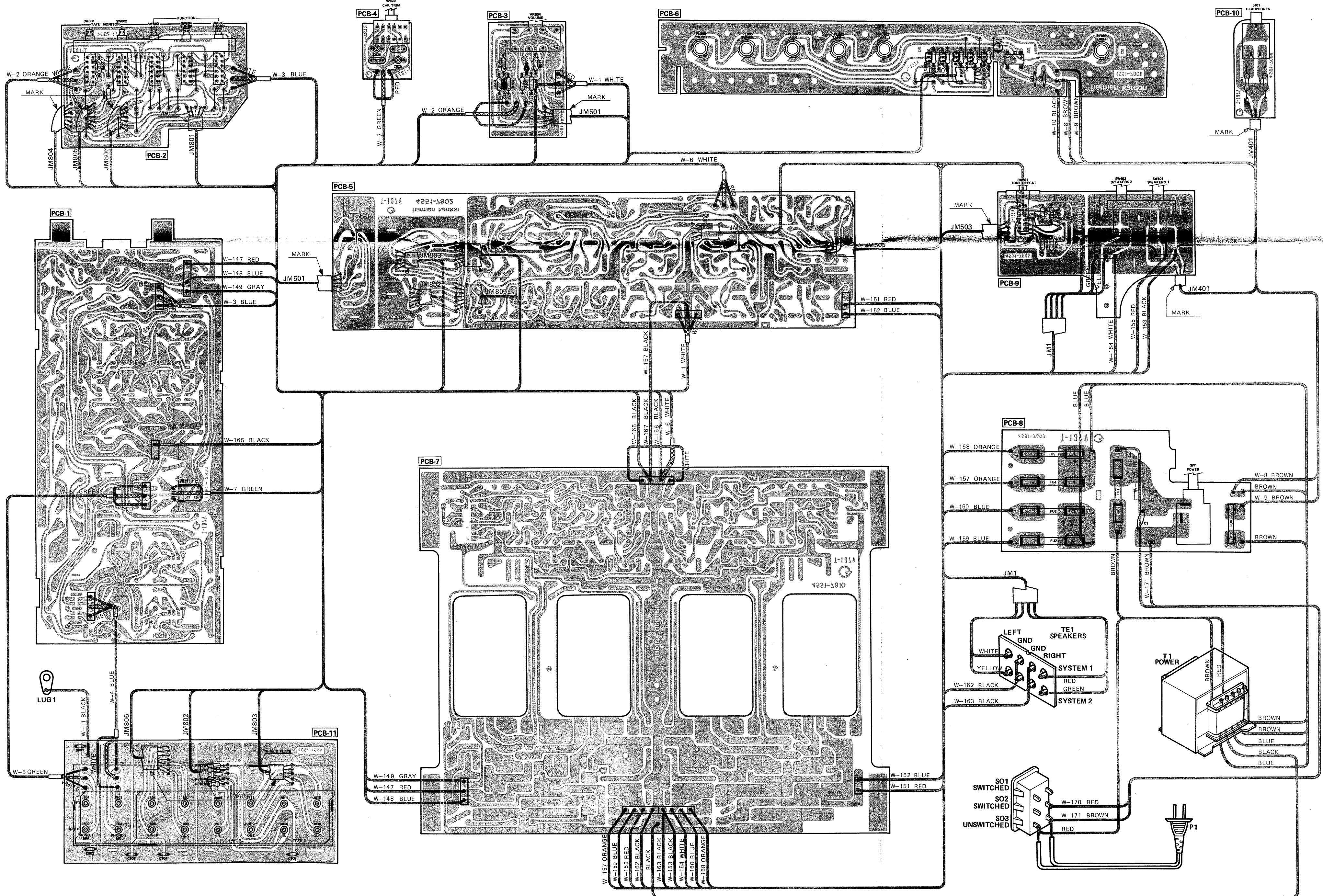

# WIRING DIAGRAM

A

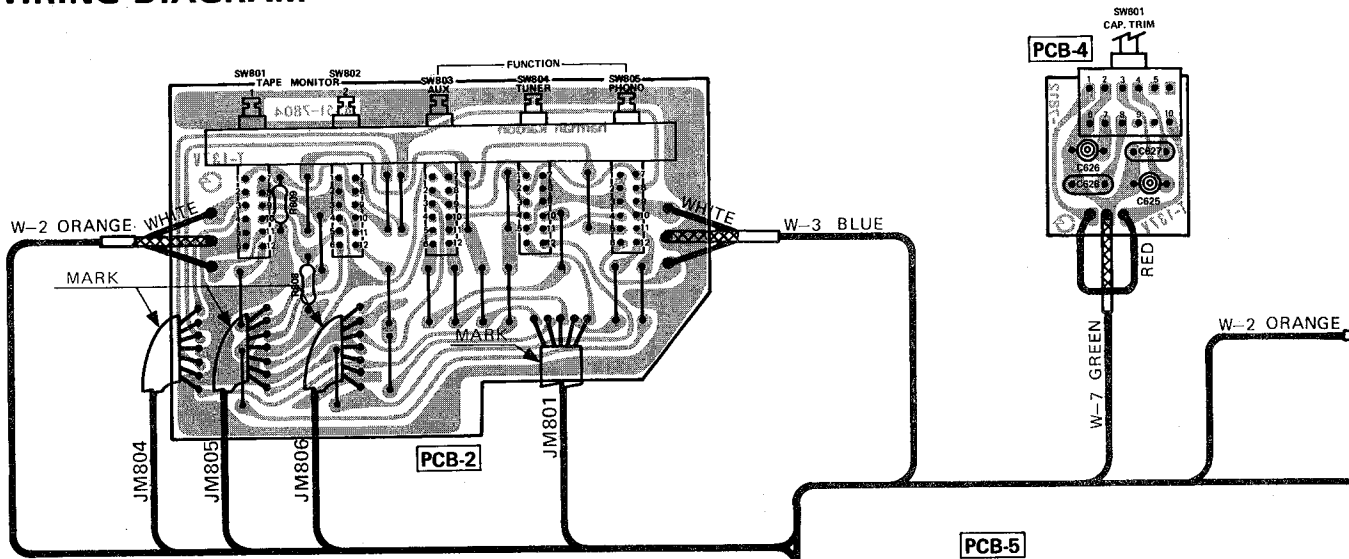

B

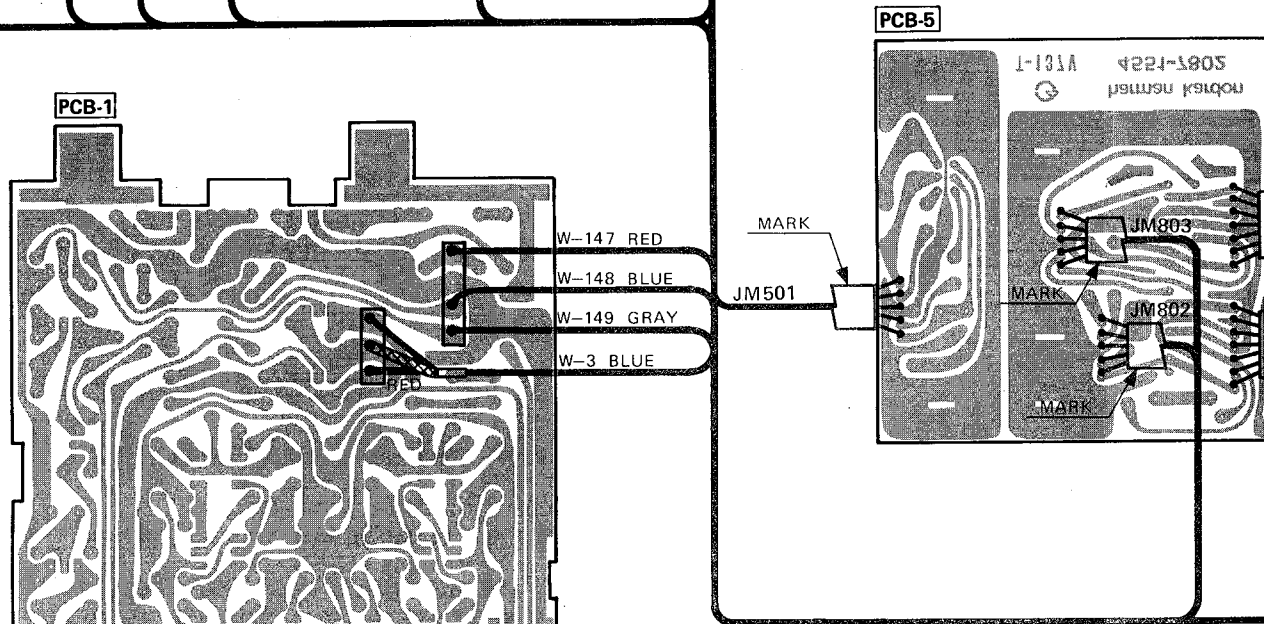

C

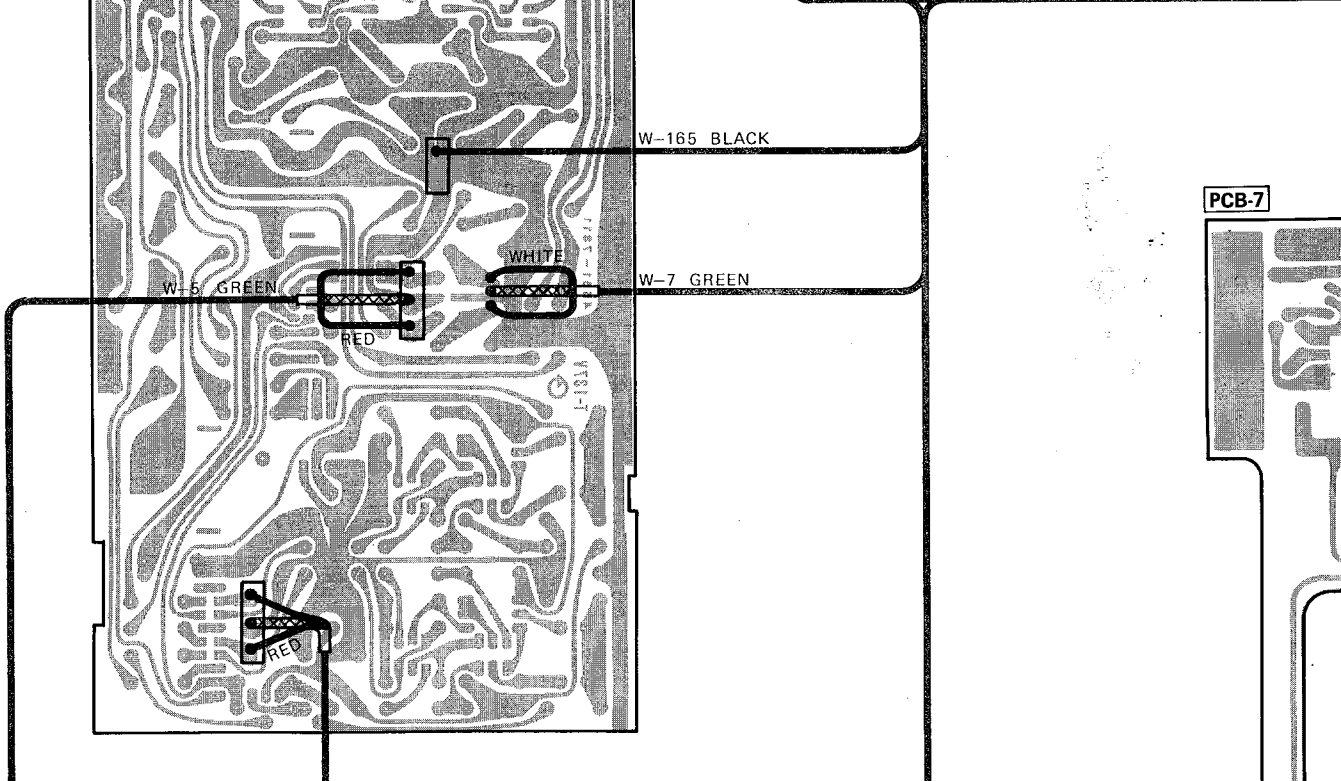

D

PCB-3

PCB-6

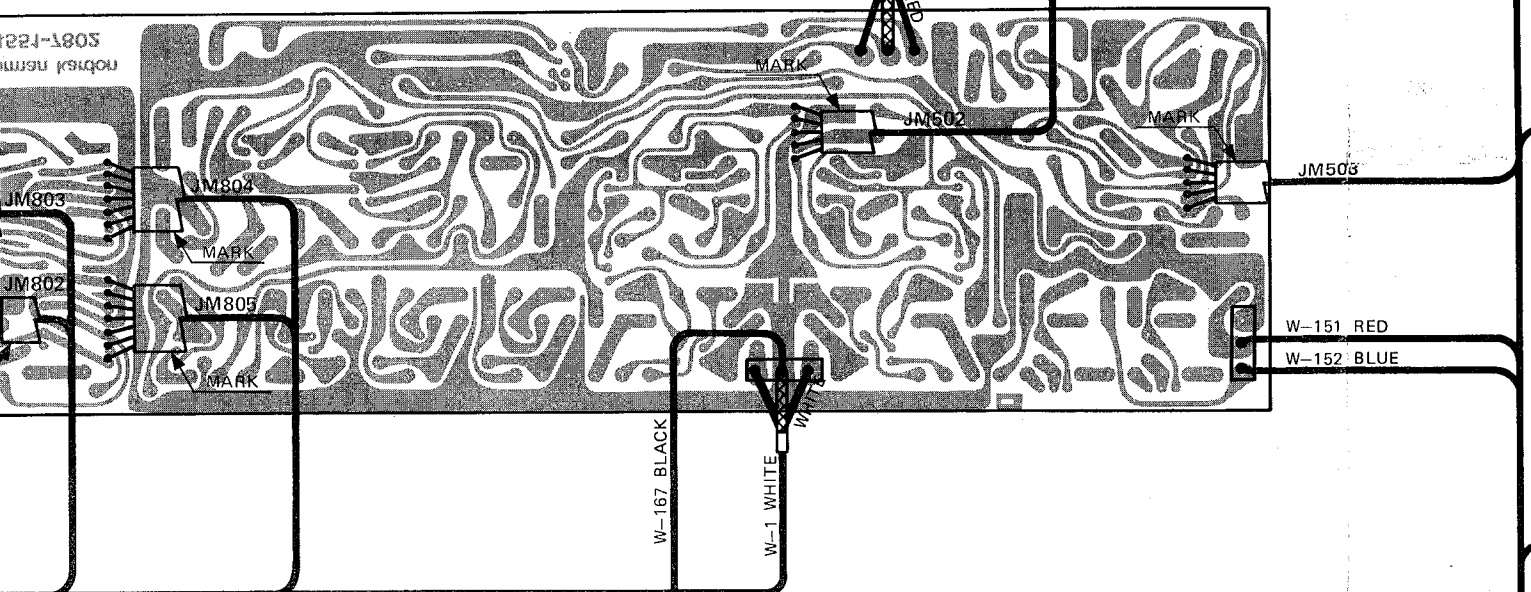
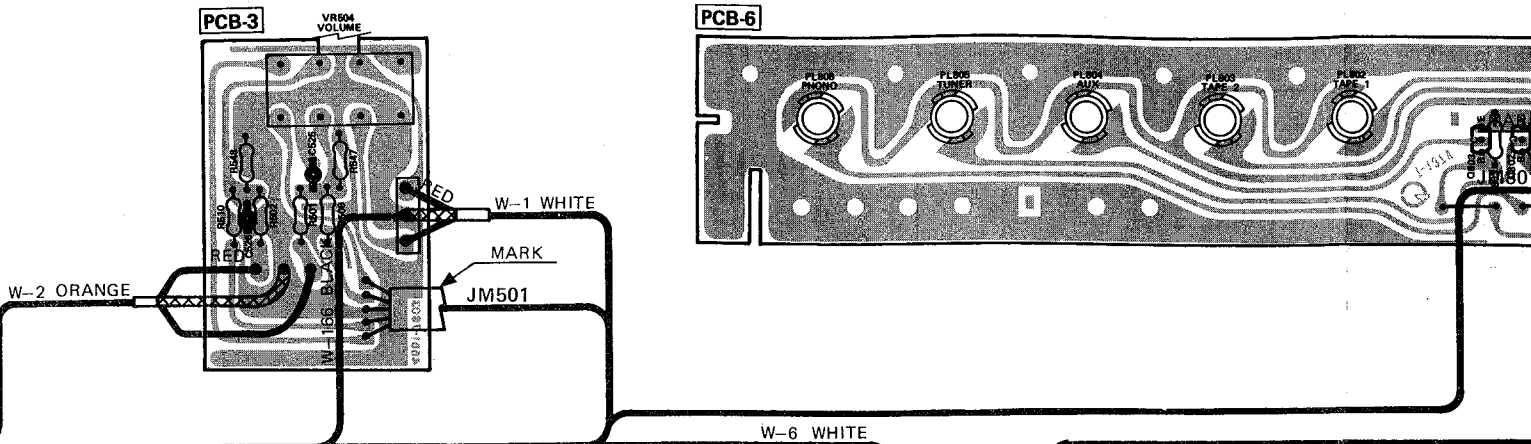

PCB-7

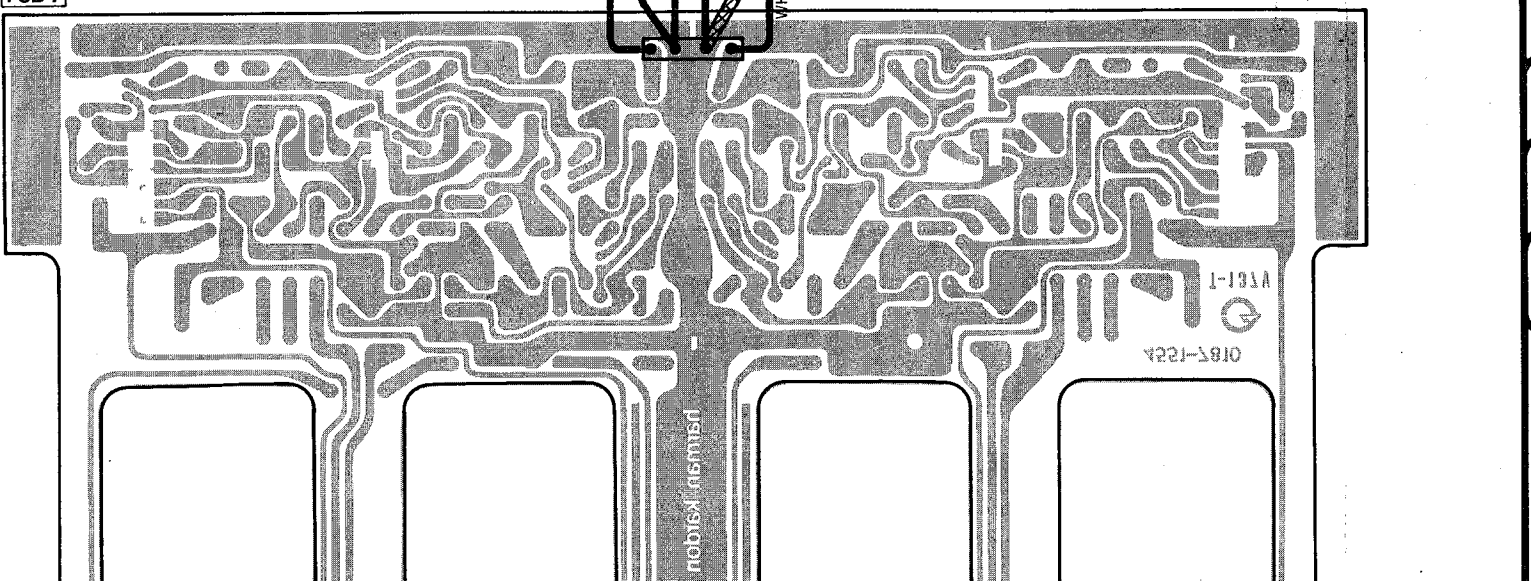



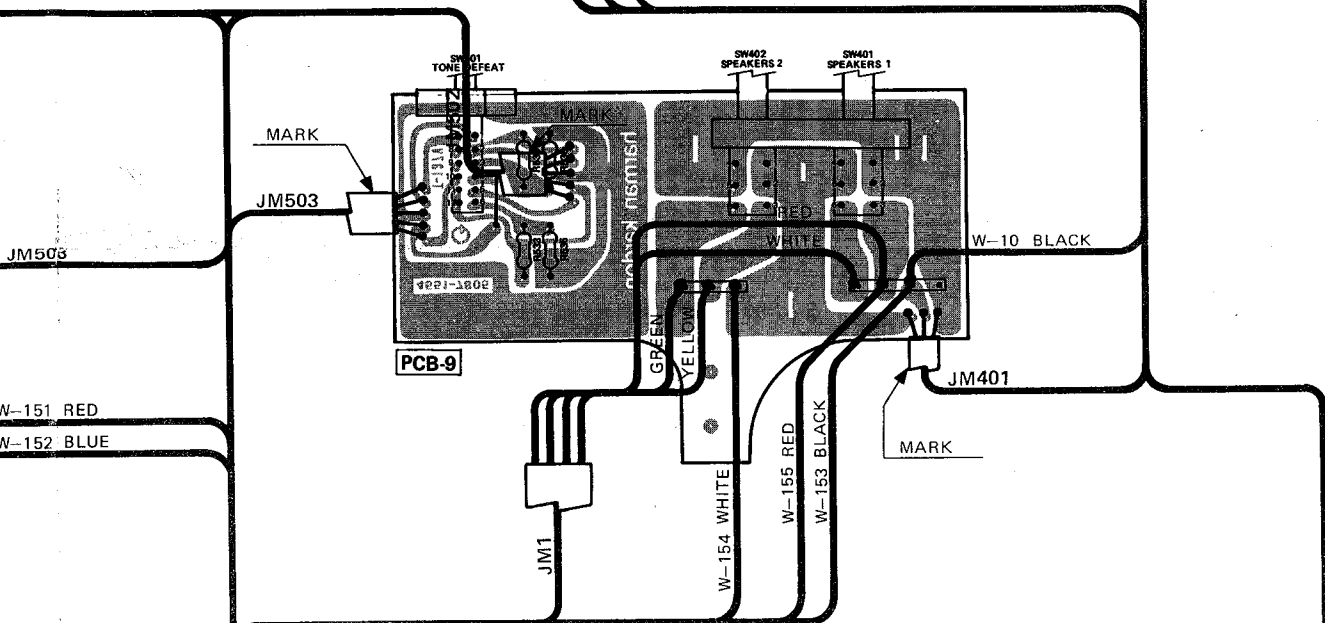
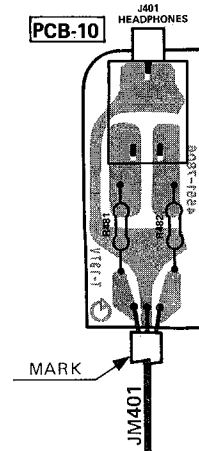
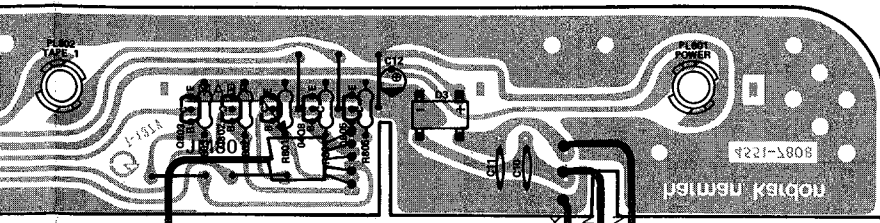

W-151 RED

W-152 BLUE

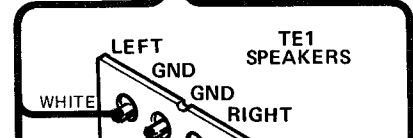
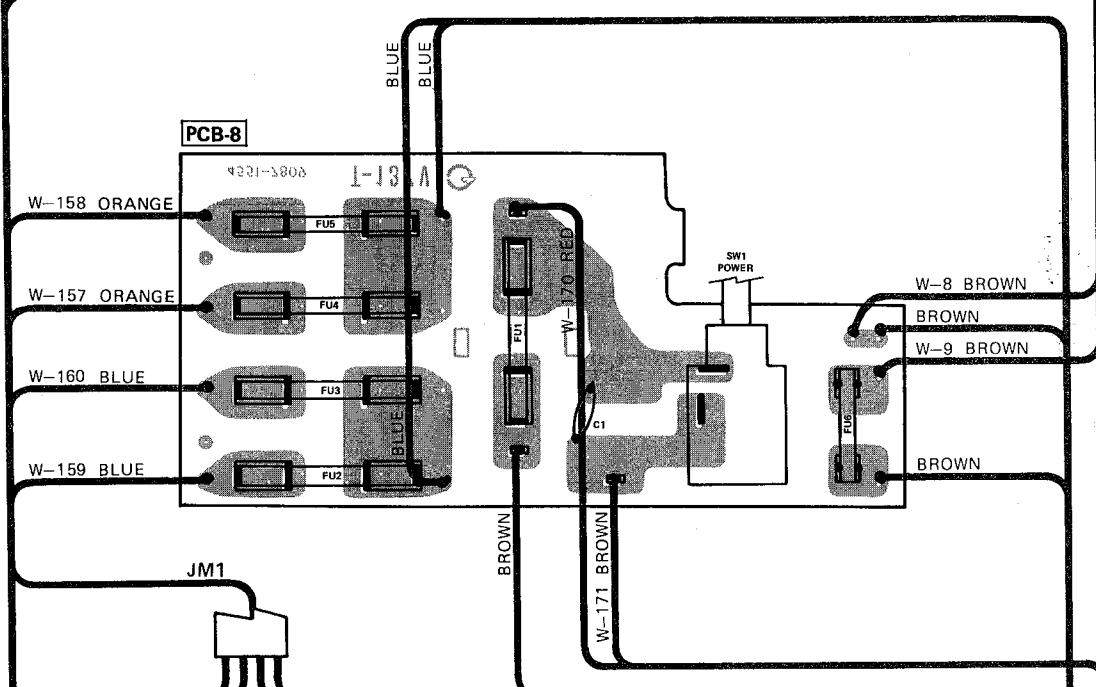

C  
D  
E  
F

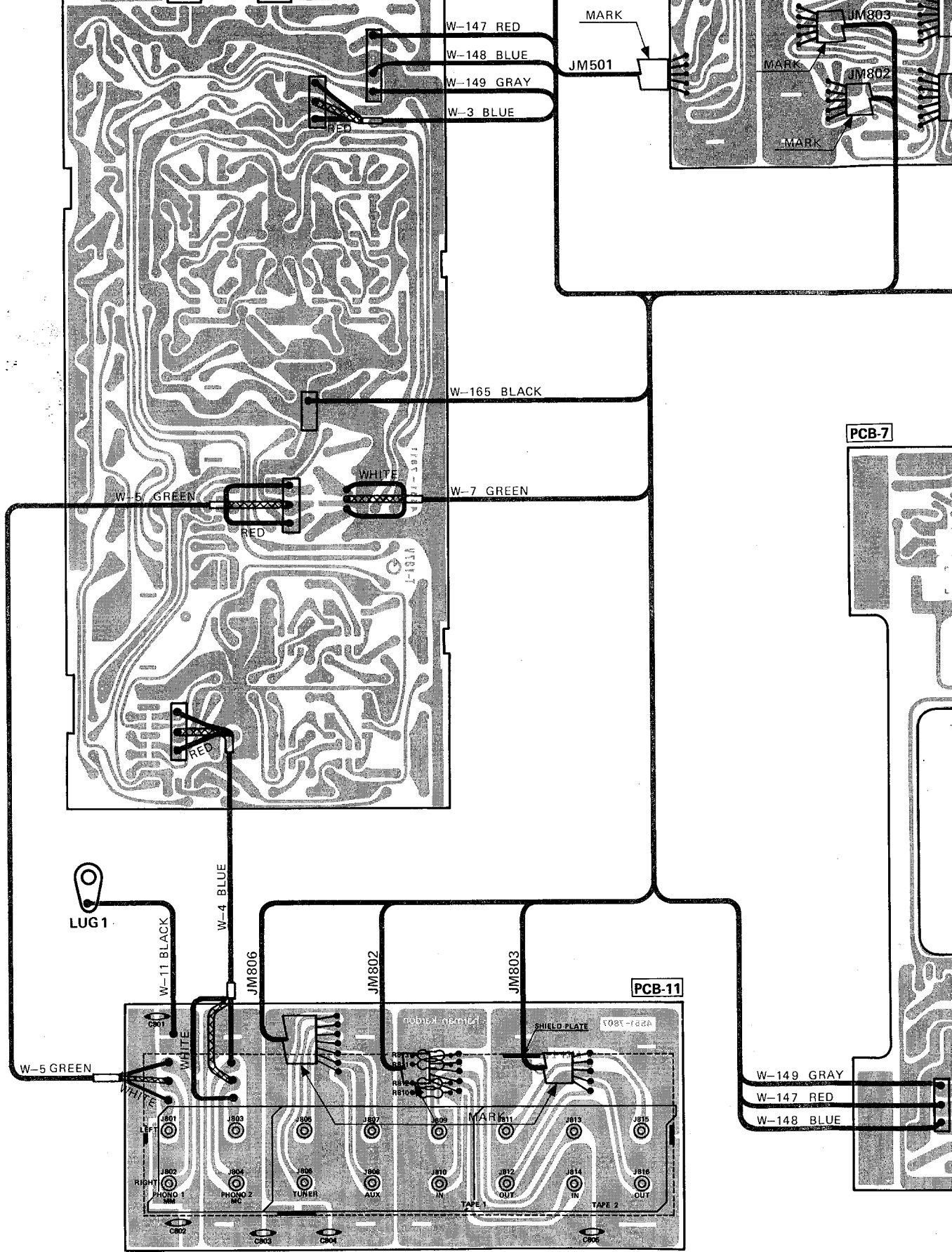

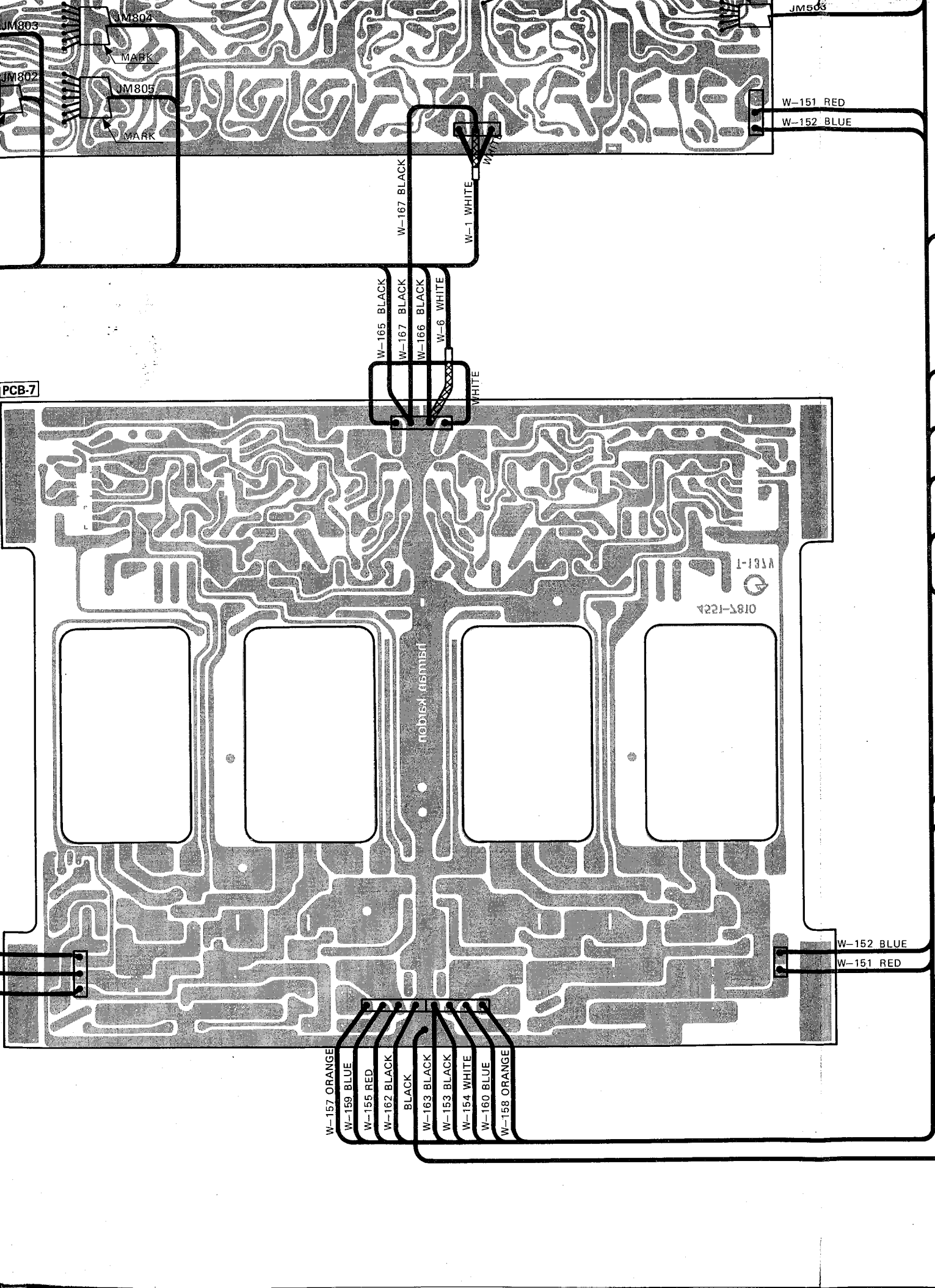

JM803

JM802

MARK

JM805

MARK

JM503

W-151 RED

W-152 BLUE

W-167 BLACK

W-1 WHITE

PCB-7

W-165 BLACK

W-167 BLACK

W-166 BLACK

W-6 WHITE

WHITE

1-131A

0183-12A

1-131A

W-152 BLUE

W-151 RED

W-157 ORANGE

W-159 BLUE

W-155 RED

W-162 BLACK

BLACK

W-163 BLACK

W-153 BLACK

W-154 WHITE

W-160 BLUE

W-158 ORANGE

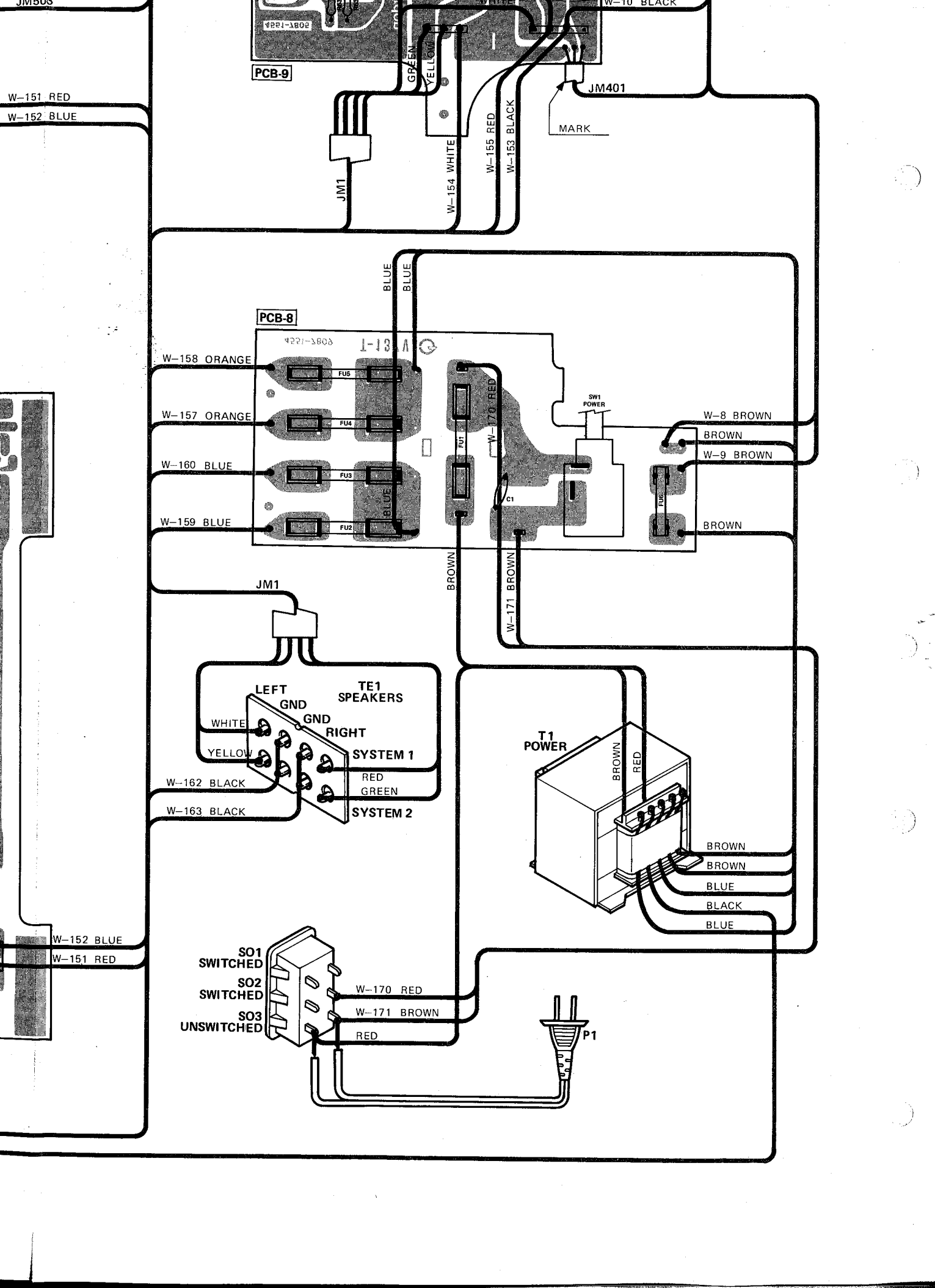

PCB-1 PHONO EQUALIZER P.C. BOARD

PCB-5 TONE CONTROL P.C. BOARD

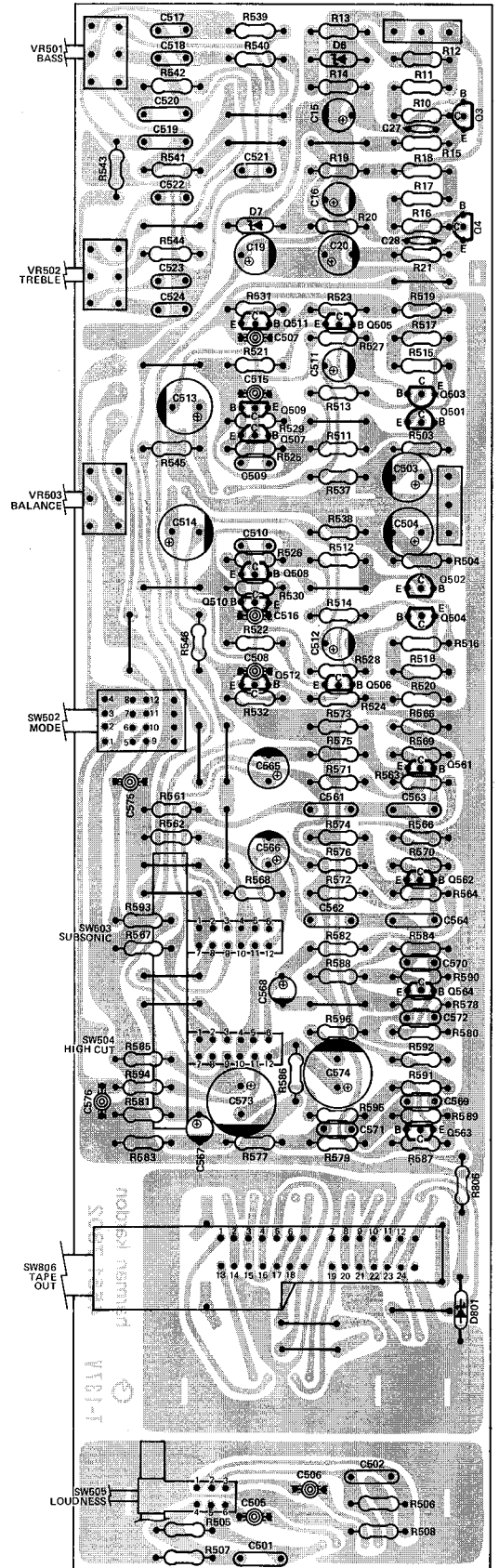
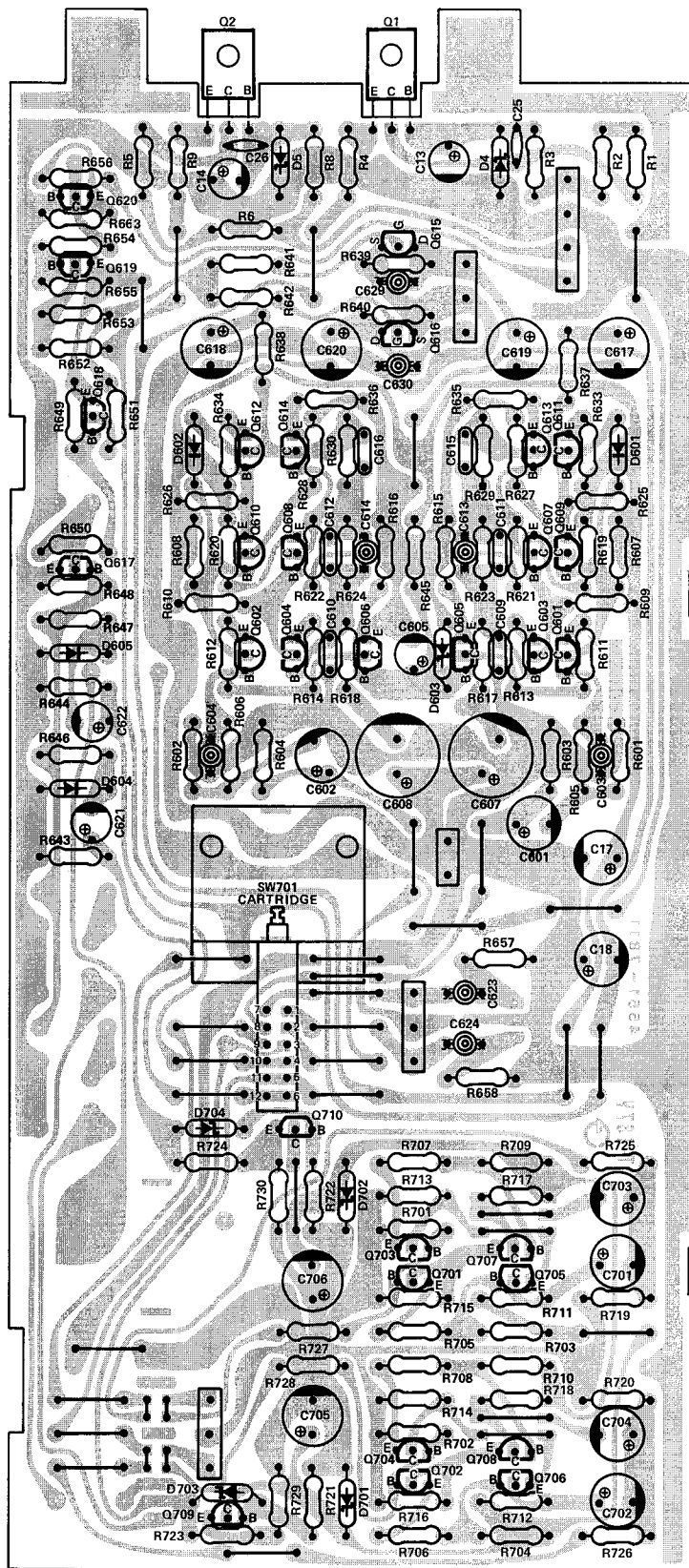

PCB-7 POWER AMP. P.C. BOARD

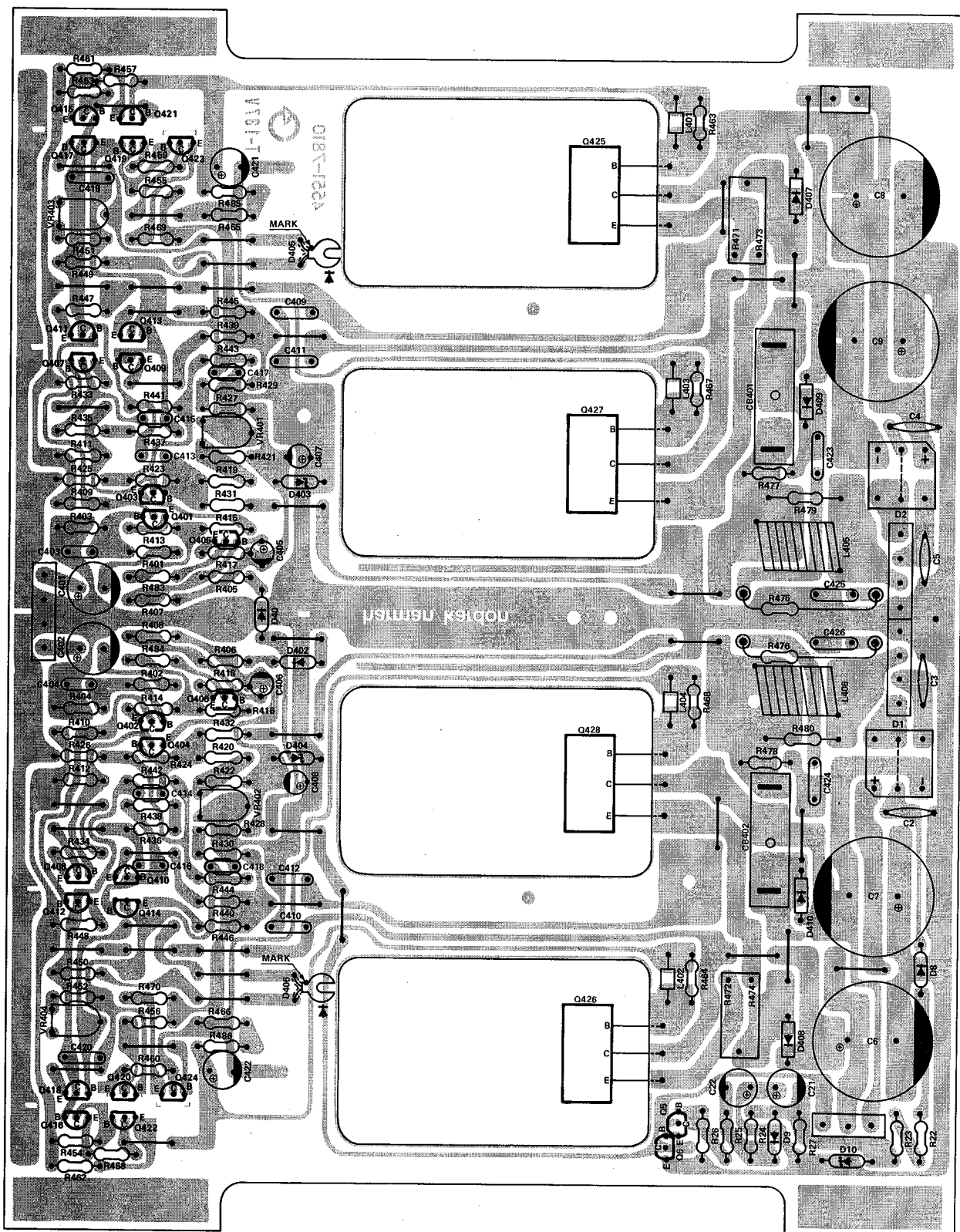

# GENERAL UNIT EXPLODED VIEW

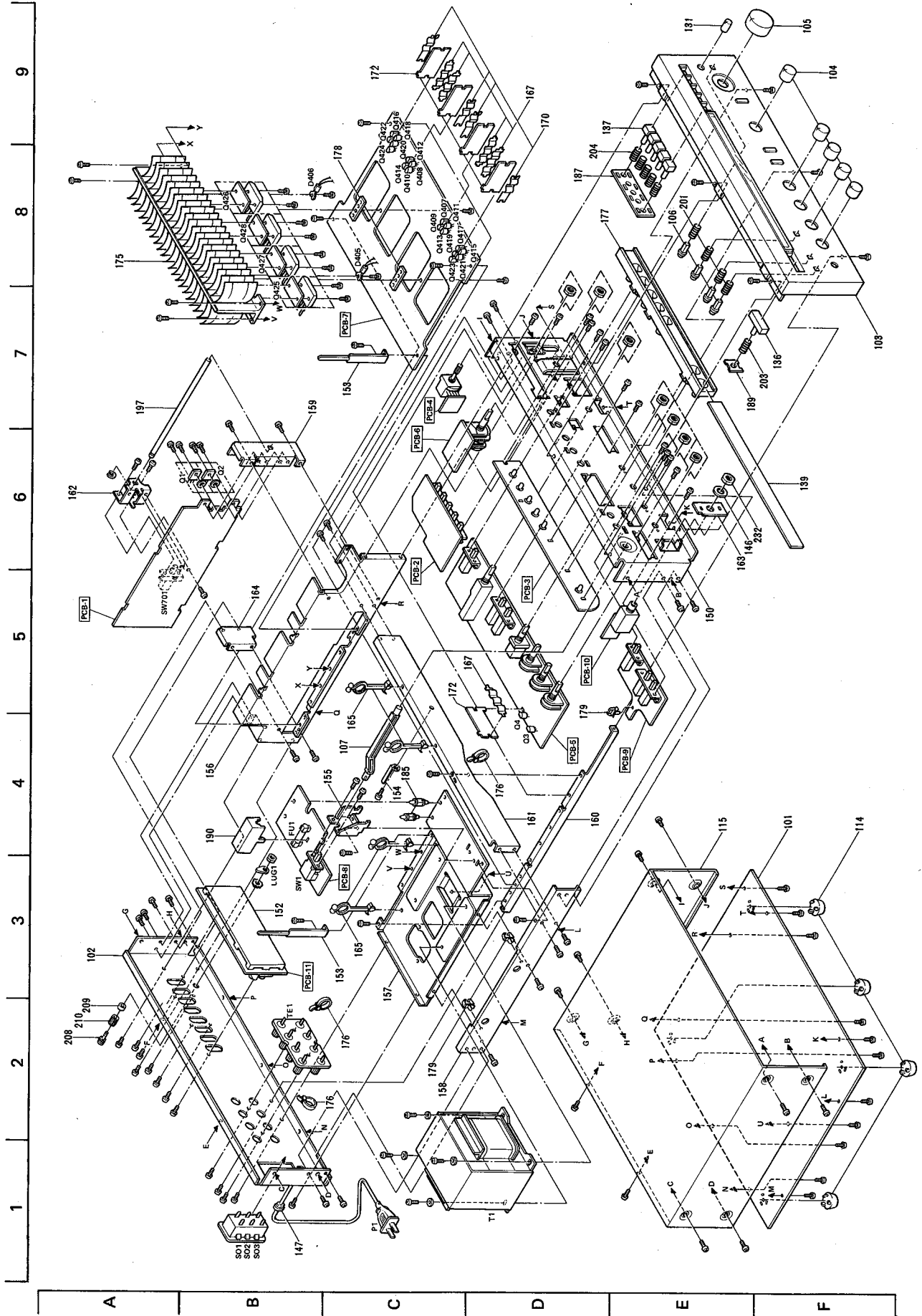

## GENERAL UNIT PARTS LIST

Ref. No.	Part No.	Description
101	A423-PM650	Cabinet Bottom Assembly
102	A424-PM650	Cabinet Back Assembly
103	A443-PM650	Front Panel Assembly (Includes: Subsonic, High Cut and Loudness Push Buttons)
104	A630-PM650-A	Knob Assembly, Bass, Treble, Balance, Mode, Tape Out
105	A630-PM650-B	Knob Assembly, Volume
106	A662-PM650	Push Button Assembly, Speakers 1, Speakers 2, Tone Defeat, Cartridge
107	B601-PM650	Shaft Assembly, Power Switch
114	1319-0139	Foot
115	1414-02401	Cabinet Top
131	1634-02701	Knob, Cap. Trim
136	1662-008001BW	Push Button, Power
137	1662-08101BW	Push Button, Tape Monitor 1/2, AUX, Tuner, Phono
139	1721-01901	Indication Plate
146	2114-72167	Bushing
147	2114-415027	Bushing
150	2211-7219	Chassis
152	2216-7117	Shield Plate
153	2218-7011	Holding Bracket
154	2218-7001	Holding Bracket
155	2219-7787	Bracket
156	2219-7788	Bracket
157	2219-7789	Bracket
158	2219-7790	Bracket
159	2219-7791	Bracket
160	2219-7792	Bracket
161	2219-7793	Bracket
162	2219-7794	Bracket
163	2219-7726	Bracket
164	2219-7816	Bracket
165	2240-7050	Holder
167	2222-7100	Heat Sink
170	2222-7101	Heat Sink
172	2222-7103	Heat Sink
175	2222-7120	Heat Sink
176	2240-7120	Holder
177	2223-7044	Reflector
178	2224-7069	Insulator
179	2224-7061	Holder
185	2240-7151	Holder
187	2240-7167	Holder
189	2240-7173	Holder
190	2240-7176	Holder
197	2601-7097	Shaft
201	2651-210187	Spring
203	2651-210196	Spring
204	2651-210195	Spring
208	2310-7015	Special Screw
209	2410-7005	Special Washer
210	2410-7011	Special Nut
232	2440-61	Special Nut



## ELECTRICAL PARTS LIST

Ref. No.	Part No.	Description
<b>CHASSIS MISCELLANEOUS</b>		
P1	4161-71147	AC Line Cord
SO1,2,3	4474-156	AC Outlets, Switched, Unswitched
T1	5584-701366	Power Transformer
TE1	4214-121	Speaker Terminals, Speaker System 1/2
JM1	4242-047025	Jumper Lead, 4-Wire
JM401	4242-030022	Jumper Lead, 3-Wire
JM501	4242-050032	Jumper Lead, 5-Wire
JM502,503	4242-050042	Jumper Lead, 5-Wire
JM801	4242-050052	Jumper Lead, 5-Wire
JM802,803	4242-050062	Jumper Lead, 5-Wire
JM804,805	4242-070052	Jumper Lead, 7-Wire
JM806	4242-070062	Jumper Lead, 7-Wire
LUG1	4211-4	Lug Terminal
<b>PCB-1 PHONO EQUALIZER P.C. BOARD</b>		
<b>RESISTORS</b>		
R2,6	5102-2704713	27 $\Omega$ , $\pm 2\%$ , 1/4W, Fuse
R617,618	5174-681381	680 $\Omega$ , $\pm 1\%$ , 1/4W, Metal
R623,624	5174-Z316228	31.6 k $\Omega$ , $\pm 0.5\%$ , 1/4W, Metal
R629,630	5174-514381	510 k $\Omega$ , $\pm 1\%$ , 1/4W, Metal
<b>CAPACITORS</b>		
C13,14	5345-476-25	47 $\mu$ F, +50% -10%, 25V, Electrolytic
C17,18	5345-107D041	100 $\mu$ F, $\pm 20\%$ , 25V, Electrolytic
C601,602	5345-476B0226	47 $\mu$ F, $\pm 20\%$ , 10V, Electrolytic
C605	5345-106-16	10 $\mu$ F, +50% -10%, 16V, Electrolytic
C607,608	5345-477B0228	470 $\mu$ F, $\pm 20\%$ , 10V, Electrolytic
C609,610	5359-182771	1800pF, $\pm 2\%$ , 50V, Polypropylene
C611,612	5359-222771	2200pF, $\pm 2\%$ , 50V, Polypropylene
C615,616	5359-822771	8200pF, $\pm 2\%$ , 50V, Polypropylene
C617,618,619,620	5345-226F0228	22 $\mu$ F, $\pm 20\%$ , 50V, Electrolytic
C621,622	5345-475D0211	4.7 $\mu$ F, $\pm 20\%$ , 25V, Electrolytic
C701,702,703,704	5345-106F0228	10 $\mu$ F, $\pm 20\%$ , 50V, Electrolytic
C705,706	5345-107C0226	100 $\mu$ F, $\pm 20\%$ , 16V, Electrolytic
<b>TRANSISTORS</b>		
Q1	5614-669(C)	2SD669(C), Voltage Regulator
Q2	5612-649(C)	2SB649(C), Voltage Regulator
Q601,602,603,604	5613-2240(BL)	2SC2240(BL),
Q605,606	5613-2603(E)or(F)	2SC2603(E) or 2SC2603(F),
Q607,608,609,610	5611-970(BL)	2SA970(BL),
Q611,612	5612-646(C)	2SB646(C),
Q613,614	5614-666(C)	2SD666(C),
Q615,616	5616-2SK163(M)or(N)	F.E.T., 2SK163(M) or 2SK163(N), Phono Muting
Q617	5613-2603(E)or(F)	2SC2603(E) or 2SC2603(F),
Q618	5611-1115(E)or(F)	2SA1115(E) or 2SA1115(F),
Q619	5611-1115(E)or(F)	2SA1115(E) or 2SA1115(F),
Q620	5613-2603(E)or(F)	2SC2603(E) or 2SC2603(F),
Q701,702,707,708	5611-1190(E)	2SA1190(E),
Q703,704,705,706	5613-2855(E)	2SC2855(E),
Q709	5611-1115(E)or(F)	2SA1115(E) or 2SA1115(F), Voltage Regulator
Q710	5613-2603(E)or(F)	2SC2603(E) or 2SC2603(F), Voltage Regulator
<b>DIODES</b>		
D4,5	5635-RD24EB2	Zener, RD24EB2
D601,602,604,605	5631-1S2473	1S2473
D603	5635-RD5R1EB1	Zener, RD5.1EB1
D701,702	5635-RD15EB2	Zener, RD15EB2
D703,704	5635-RD3R0EB1	Zener, RD3.0EB1
<b>MISCELLANEOUS</b>		
SW701	4431-01048494	Push Switch, Cartridge

Ref. No.	Part No.	Description
<b>PCB-2 FUNCTION SWITCH P.C. BOARD</b>		
SW801,802,803,804, 805	4431-05207247	Push Switch, Tape Monitor 1, Tape Monitor 2, AUX, Tuner, Phono
<b>PCB-3 INDICATION LAMP P.C. BOARD</b>		
<b>CAPACITORS</b>		
C12	5345-105-50	1 $\mu$ F, +75% -10%, 50V, Electrolytic
<b>TRANSISTORS</b>		
Q801,802,803,804, 805	5613-2603(E)or(F)	2SC2603(E) or 2SC2603(F), Switching
<b>DIODES</b>		
D3	5685-S1WB10	Bridge Silicon, S1WB10
<b>MISCELLANEOUS</b>		
PL801,802,803,804, 805,806	5731-1407154	Lamp, 36mA, 110V
<b>PCB-4 CAP. TRIM SWITCH P.C. BOARD</b>		
SW601	4411-204713	Rotary Switch, Cap. Trim
C627,628	5353-680534	Capacitor, 68pF, $\pm$ 5%, 500V, Mica
<b>PCB-5 TONE CONTROL P.C. BOARD</b>		
<b>RESISTORS</b>		
R12,18	5102-8204713	82 $\Omega$ , $\pm$ 2%, 1/4W, Fuse
<b>CONTROLS</b>		
VR501	5113-10482122	100 k $\Omega$ (C), Bass Control
VR502	5113-50383122	50 k $\Omega$ (C), Treble Control
VR503	5113-50381122	50 k $\Omega$ (M,N), Balance Control
<b>CAPACITORS</b>		
C15,16	5345-476-25	47 $\mu$ F, +50% -10%, 25V, Electrolytic
C19,20	5345-107D041	100 $\mu$ F, +50% -10%, 25V, Electrolytic
C503,504	5345-226F0228	22 $\mu$ F, $\pm$ 20%, 50V, Electrolytic
C509,510	5353-050934	5pF, $\pm$ 0.5pF, 500V, Mica
C511,512	5345-336B0226	33 $\mu$ F, $\pm$ 20%, 10V, Electrolytic
C513,514	5345-107F0228	100 $\mu$ F, $\pm$ 20%, 50V, Electrolytic
C565,566	5345-226C0951	22 $\mu$ F, $\pm$ 20%, 16V, Electrolytic
C567,568	5345-106C0951	10 $\mu$ F, $\pm$ 20%, 16V, Electrolytic
C573,574	5345-107B0951	100 $\mu$ F, $\pm$ 20%, 10V, Electrolytic
<b>TRANSISTORS</b>		
Q3	5614-667(C)	2SD667(C), Voltage Regulator
Q4	5612-647(C)	2SB647(C), Voltage Regulator
Q501,502,503,504	5613-2320L(F)or(G)	2SC2320L(F) or 2SC2320L(G),
Q505,506,507,508, 509,510	5611-1115(E)or(F)	2SA1115(E) or 2SA1115(F),
Q511,512	5613-2603(E)or(F)	2SC2603(E) or 2SC2603(F),
Q561,562,563,564	5613-2603(E)	2SC2603(E), Subsonic Filter, High-Cut Filter
<b>DIODES</b>		
D6,7	5635-RD20EB1	Zener, RD20EB1
D801	5635-RD3R0EB1	Zener, RD3.0EB1
<b>MISCELLANEOUS</b>		
SW502	4411-403711	Rotary Switch, Mode
SW503,504	4431-02087759	Push Switch, Subsonic, High Cut
SW505	4431-01028694	Push Switch, Loudness
SW806	4412-045732	Rotary Slide Switch, Tape Out
<b>PCB-6 VOLUME CONTROL P.C. BOARD</b>		
VR504	5116-1047343	Variable Resistor, 100 k $\Omega$ (B), Volume Control

} Flat/Tone Control Amp.

Ref. No.	Part No.	Description
<b>PCB-7 POWER AMP. P.C. BOARD</b>		
<b>RESISTORS</b>		
R423,424	5174-681381	680 Ω, ±1%, 1/4W, Metal
R425,426	5174-470381	47 Ω, ±1%, 1/4W, Metal
R431,432	5174-243381	24 kΩ, ±1%, 1/4W, Metal
R433,434,439,440, 445,446,447,448, 453,454,455,456	5102-1014713	100 Ω ±2%, 1/4W, Fuse
R449,450	5102-8214713	820 Ω, ±2%, 1/4W, Fuse
R457,458,459,460	5102-1504713	15 Ω, ±2%, 1/4W, Fuse
R461,462,469,470	5102-2R2579	2.2 Ω, ±5%, 1/4W, Fuse
R471/473,472/474	5273-R22672	0.22 Ω, ±10%, 3W x 2, Cement (Special Dual)
R475,476	5175-220571	22 Ω, ±5%, 3W, Metal
R479,480	5171-270581	27 Ω, ±5%, 1W, Metal
R485,486	5102-3304713	33 Ω, ±2%, 1/4W, Fuse
<b>CONTROLS</b>		
VR401,402	5101-10471913	100 kΩ (B)
VR403,404	5101-10271913	1 kΩ (B)
<b>CAPACITORS</b>		
C6,7,8,9	5341-478F0051	4700μF, ±20%, 50V, Electrolytic
C21	5345-336C0211	33μF, ±20%, 16V, Electrolytic
C22	5345-107C0211	100μF, ±20%, 16V, Electrolytic
C401,402	5345-107F0228	100μF, ±20%, 50V, Electrolytic
C403,404	5353-820534	82pF, ±5%, 500V, Mica
C405,406	5345-474-50	0.47μF, +75% -10%, 50V, Electrolytic
C407,408	5345-226-16	22μF, +50% -10%, 16V, Electrolytic
C413,414	5353-050934	5pF, ±0.5pF, 500V, Mica
C421,422	5345-106F0226	10μF, ±20%, 50V, Electrolytic
<b>TRANSISTORS</b>		
Q5,6	5611-1115(E)or(F)	2SA1115(E) or 2SA1115(F), Audio Muting
Q401,402,403,404	5613-2240(BL)	2SC2240(BL),
Q405,406	5613-2603(F)	2SC2603(F),
Q407,408,411,412	5611-949(Y)	2SA949(Y),
Q409,410,413,414	5613-2229(Y)	2SC2229(Y),
Q415,416,423,424	5613-2235(O)	2SC2235(O),
Q417,418	5613-945(K)	2SC945(K),
Q419,420,421,422	5611-965(O)	2SA965(O),
Q425,426	5613-2773(O)or(Y)	2SC2773(O) or 2SC2773(Y),
Q427,428	5611-1169(O)or(Y)	2SA1169(O) or 2SA1169(Y),
<b>DIODES</b>		
D1,2	5685-S3WB20F4	Bridge Silicon, S3WB20
D8	5636-1S2471	1S2471
D9	5636-1S2472	1S2472
D10	5635-RD12EB2	Zener, RD12EB2
D401,402	5631-1S2473	1S2473
D403,404	5635-RD15EB2	Zener, RD15EB2
D405,406	5641-MV12YM	Varistor, MV12YM
D407,408,409,410	5632-ERB12-02	Zener, ERB12-02
<b>COILS</b>		
L401,402,403,404	5597-35502	Ferrite Bead
L405,406	5991-7125	RF Choke
<b>MISCELLANEOUS</b>		
CB401,402	4361-312014 2132-291	Speaker Protector Spacer, R475, R476

Power Amp.

**PCB-8 FUSE P.C. BOARD**

SW1	4431-01017358	Push Switch, Power
FU1	5732-402029	Fuse, 4A, 125V
FU2,3,4,5	5732-502029	Fuse, 5A, 125V
FU6	5732-401031	Fuse, 400mA, 125V
C1	5361-1030419	Capacitor, 0.01μF, +100% -0%, AC125V, Ceramic
	4472-7113	Fuse Holder, FU1~5
	4472-7122	Fuse Holder, FU6

Ref. No.	Part No.	Description
<b>PCB-9 SPEAKERS AND TONE DEFEAT SWITCHES P.C. BOARD</b>		
SW401,402	4431-02047451	Push Switch, Speakers 1, Speakers 2
SW501	4431-01047994	Push Switch, Tone Defeat
<b>PCB-10 HEADPHONES JACK P.C. BOARD</b>		
R481,482	5171-471581	Resistor, 470 ohm, ±5%, 1W, Metal
J401	4451-00121	Jack, Headphones
<b>PCB-11 PIN JACK P.C. BOARD</b>		
J801,802,803,804	4484-27	4-Pin Jack, Phono 1, Phono 2
J805,806,807,808, 809,810,811,812, 813,814,815,816	4486-8	6-Pin Jack, Tuner, AUX, Tape 1, Tape 2

**PACKAGE**

